

Kramer Electronics, Ltd.

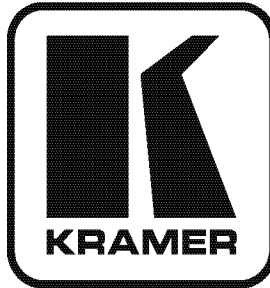

USER MANUAL

Model:

VP-725xl

Presentation Switcher / Scaler

Contents

1	Introduction	1
2	Getting Started	1
2.1	Quick Start	1
3	Overview	3
3.1	About HDMI	5
4	Your VP-725xl Presentation Switcher / Scaler	5
5	Installing in a Rack	10
6	Connecting the VP-725xl Presentation Switcher / Scaler	11
6.1	Connecting the VP-725xl	11
6.2	The RGBS and RGsB PINOUTs	13
6.3	Connecting a PC	13
6.4	Connecting the VP-725xl via the ETHERNET port	14
6.4.1	Connecting the ETHERNET Port directly to a PC (Crossover Cable)	14
6.4.2	Connecting the ETHERNET Port via a Network Hub (Straight-Through Cable)	15
7	Operating the Presentation Switcher / Scaler	15
7.1	Switching an Input in the Video Group Mode/Scaler Mode	16
7.2	Understanding the PIP Feature	16
7.3	Locking and Unlocking the Front Panel	17
7.4	Freezing the Image	18
7.5	Displaying a Blank Screen	18
8	Configuring and Controlling the VP-725xl	19
8.1	Configuring the VP-725xl via the OSD MENU Screens	19
8.1.1	The Input Screen	20
8.1.2	The Picture Screen	21
8.1.3	The Output Screen	22
8.1.4	The PIP Screen	23
8.1.5	The Geometry Screen	24
8.1.6	The Setup Screen	25
8.1.7	The Slideshow Feature	26
8.1.7.1	The Advanced Setup Screen	27
8.1.8	Verifying Configuration Details via the Info Screen	30
8.2	Operating via the LCD Display	31
8.3	Operating via the Infrared Remote Control Transmitter	31
8.4	Operating via ETHERNET/Serial Port	33
9	Using Text Overlay	33
10	Technical Specifications	35
11	VP-725xl Communication Protocol	38
11.1	Error Codes	49

Figures

Figure 1: VP-725xl Presentation Switcher / Scaler Front Panel	6
Figure 2: VP-725xl Presentation Switcher / Scaler Rear Panel	8
Figure 3: Connecting the VP-725xl Presentation Switcher / Scaler	12
Figure 4: Connecting the PC	13
Figure 5: Local Area Connection Properties Window	14
Figure 6: Internet Protocol (TCP/IP) Properties Window	15
Figure 7: MENU Items	19
Figure 8: Input Screen	20
Figure 9: Picture Screen	21
Figure 10: Output Screen	22
Figure 11: PIP Screen	23
Figure 12: Geometry Screen	24
Figure 13: Setup Screen	25
Figure 14: Advanced Setup Screen	27
Figure 15: Misc Setup Screen	27
Figure 16: Input Setup Screen	29
Figure 17: Output Setup Screen	29
Figure 18: Information Screen	30
Figure 19: Example of how to use the LCD Display	31
Figure 20: Infrared Remote Control Transmitter	32
Figure 21: TextOverlay Application Screen	33

Tables

Table 1: Front Panel VP-725xl Presentation Switcher / Scaler Features	7
Table 2: Rear Panel VP-725xl Presentation Switcher / Scaler Features	9
Table 3: RGBS and RGsB PINOUTS	13
Table 4: PIP Source Appearance Availability	16
Table 5: Input Screen Functions	20
Table 6: Picture Screen Functions	21
Table 7: Output Screen Functions	22
Table 8: PIP Screen Functions	23
Table 9: Geometry Screen Functions	24
Table 10: Available Settings for Each Application	25
Table 11: Setup Screen Functions	25
Table 12: Mode Set Functions	27
Table 13: OSD Functions	27
Table 14: Misc Functions	28
Table 15: Input Functions	29
Table 16: Output Functions	30
Table 17: Infrared Remote Control Transmitter Functions	32
Table 18: Features and Functions of the TextOverlay Application	34
Table 19: Technical Specifications of the VP-725xl Presentation Switcher / Scaler	35
Table 20: Technical Specifications of the RGBHV / RGBS (PC) / RGsB (PC) Input Signal	36
Table 21: Technical Specifications of the Y/C, Video Signal	36
Table 22: Technical Specifications of the HDMI input Signal (for RGB or YUV Colorspace)	36

Contents

Table 23: Technical Specifications of the Component Input Signal	37
Table 24: Technical Specifications of the RGBHV/Comp/YPbPr Output Signal	37
Table 25: Communication Protocol of the VP-725xl	39
Table 26: The Error Codes	49

1 Introduction

Welcome to Kramer Electronics! Since 1981, Kramer Electronics has been providing a world of unique, creative, and affordable solutions to the vast range of problems that confront the video, audio, presentation, and broadcasting professional on a daily basis. In recent years, we have redesigned and upgraded most of our line, making the best even better! Our 1,000-plus different models now appear in 11 groups¹ that are clearly defined by function.

Congratulations on purchasing your Kramer **VP-725x1 Presentation Switcher / Scaler**, which is ideal for the following typical applications:

- Projection systems (with full audio capability) in conference rooms, board rooms, auditoriums, hotels, and churches
- Any application in which high quality conversion and switching of multiple and different video signals to graphical data is required for projection and large display purposes (with full audio capability)

The package includes these items:

- **VP-725x1 Presentation Switcher / Scaler**
- Power cord²
- Infrared remote control transmitter (including the required battery)
- Null-modem adapter and this user manual³

2 Getting Started

We recommend that you:

- Unpack the equipment carefully and save the original box and packaging materials for possible future shipment
- Review the contents of this user manual
- Use Kramer high performance high resolution cables⁴

2.1 Quick Start

This quick start chart summarizes the basic setup and operation steps.

1 GROUP 1: Distribution Amplifiers; GROUP 2: Switchers and Matrix Switchers; GROUP 3: Control Systems; GROUP 4: Format/Standards Converters; GROUP 5: Range Extenders and Repeaters; GROUP 6: Specialty AV Products; GROUP 7: Scan Converters and Scalers; GROUP 8: Cables and Connectors; GROUP 9: Room Connectivity; GROUP 10: Accessories and Rack Adapters; GROUP 11: Sierra Products

2 We recommend that you use only the power cord that is supplied with the machine

3 Download up-to-date Kramer user manuals from the Internet at this URL: <http://www.kramerelectronics.com>

4 The complete list of Kramer cables is on our Web site at <http://www.kramerelectronics.com>

Step 1: Mount the machine - see section 5

Mount the machine in a rack
or stick the 4 rubber feet
to the underside



Step 2: Connect the inputs and outputs - see section 6

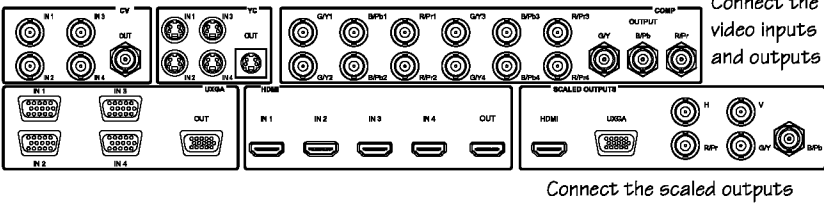

Step 3: Connect the control port - see section 6

If needed, connect an RS-232 Control Port, and/or the ETHERNET Port

Step 4: Turn the power ON

Step 5: Operate the machine - see sections 7 and 8

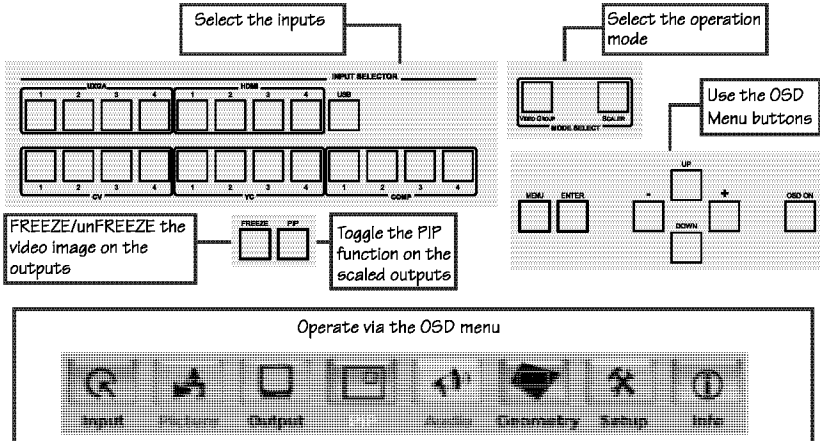

Operate via the front panel buttons, OSD, Ethernet IR remote control and/or RS-232

3 Overview

The **VP-725xl** is a presentation scaler/switcher with multiple signal format sections. The unit has five independent 4x1 video sections: composite, s-Video (Y/C), component (YUV), computer graphics, and HDMI, plus a single USB input. It also scales any video input up or down to a selectable graphics or HDTV output resolution and provides glitch-free switching between sources through FTB™ (fade-thru-black) switching technology.

In particular, the **VP-725xl**:

- Features Silicon Optix HQV® Video Processing (Hollywood Quality Video) which represents the state-of-the-art in video processing technology, with the highest quality de-interlacing, noise reduction, and scaling performance for both standard-definition and high-definition signals
- Features high-quality 3:2 and 2:2 pull down, de-interlacing and full up- and down-scaling of computer graphics video input signals¹
- Is HDTV Compatible and HDCP compliant²
- Includes Fade-Thru-Black (FTB™) Switching – The video fades to black and then the new input fades from black for smooth, glitch-free switching. The output signal provides constant sync so the display never glitches
- Features K-IIT XL™ Picture-in-Picture Image Insertion Technology – Ultra stable picture-in-picture, picture-and-picture, and split screen capability. Any video source can be inserted into or positioned next to a computer graphics video source or vice versa with window positioning and sizing controls³
- Supports Multi-Formats – Auto, NTSC (3.58/4.43), PAL (M/N/60) and SECAM
- Includes six switchers in one – Five 4x1 dedicated signal format switchers (4x1 composite, 4x1 s-Video (Y/C), 4x1 component (RGB/YUV), 4x1 computer graphics (15-pin HD), 4x1 HDMI) and one 21x1:3 scaled output switcher
- Includes scaled computer & HDTV outputs – A single output signal in three formats (15-pin HD, RGBHV, and HDMI) simultaneously
- Includes HDTV output resolutions – 720p, 1080i, and 1080p
- Includes USB port on front panel for reading and displaying JPEG picture files

1 Accommodates the frame-rate of a converted movie (24 frames per second) to video frequencies (25 frames per second (PAL); 30 frames per second (NTSC))

2 The HDCP (High Definition Content Protection) license agreement allows only copy-protected data on the HDMI input to pass to the HDMI output

3 See section 7.2

- Features multiple color space – RGB or YUV output
- Supports embedded audio on the HDMI inputs and outputs
- Features Projector Anywhere™ technology – horizontal & vertical geometry controls that compensate for off-axis projector placement
- Supports a wide choice of computer graphics output resolutions up to WUXGA/1080p, plus user-definable custom output resolutions¹ with selectable refresh rates
- Provides multiple aspect ratio selections: standard, letterbox, follow output, virtual wide, follow input, and user definable settings
- Includes built-in ProcAmp: color, hue, sharpness, contrast, and brightness are set individually for each input
- Features a built-in time base corrector that stabilizes the sync in unstable video sources
- Features front panel freeze frame
- Features video blanking, with a selectable blue or black screen
- Enables screenshot capture
- Scales and zooms (to up to 400% of the original size)
- Can be firmware upgraded in the field via the USB port on the front panel
- Includes worldwide power supply – 100-240V AC on a standard 19" rack mount size, 3U Rack "ears" included
- HDMI channel supports up to 2.25Gbps bandwidth per graphic channel²

Control the **VP-725xl** from the front panel and a user-friendly menu-driven OSD (see section 8.1), or:

- From the front panel high contrast LCD Display (see section 8.2)
- Remotely, from the infrared remote control transmitter (see section 8.3)
- Via the Ethernet (see section 8.4)
- Remotely, via RS-232 (see section 6.3)

Achieving the best performance means:

- Connecting only good quality connection cables, thus avoiding interference, deterioration in signal quality due to poor matching, and elevated noise levels (often associated with low quality cables)
- Avoiding interference from neighboring electrical appliances, making sure not to block the ventilation holes, and positioning your **VP-725xl** away from moisture, excessive sunlight and dust

¹ Recommended for advanced users only – non-standard settings may not be recognized by the display device

² Suitable for resolutions up to UXGA at 60Hz, and for all HD resolutions

3.1 About HDMI

High-Definition Multimedia Interface (HDMI) is an uncompressed all-digital¹ audio/video interface, widely supported in the entertainment and home cinema industry. It delivers the maximum high-definition image and sound quality in use today. Note that Kramer Electronics Limited is an HDMI Adopter² and an HDCP Licensee³.

In particular, HDMI⁴:

- Provides a simple⁵ interface between any audio/video source, such as a set-top box, DVD player, or A/V receiver and video monitor, such as a digital flat LCD / plasma television (DTV), over a single lengthy⁶ cable
- Supports standard, enhanced, high-definition video, and multi-channel digital audio⁷ on a single cable
- Transmits all ATSC HDTV standards and supports 8-channel digital audio, with bandwidth to spare to accommodate future enhancements and requirements
- Benefits consumers by providing superior, uncompressed digital video quality via a single cable⁸, and user-friendly connector
- Is backward-compatible with DVI (Digital Visual Interface)
- Supports two-way communication between the video source (such as a DVD player) and the digital television, enabling new functionality such as automatic configuration and one-button play
- Has the capacity to support existing high-definition video formats (720p, 1080i, and 1080p/60), standard definition formats such as NTSC or PAL, as well as 480p and 576p

4 Your VP-725xl Presentation Switcher / Scaler

Figure 1 and Table 1 define the front panel of the **VP-725xl**:

1 Ensuring an all-digital rendering of video without the losses associated with analog interfaces and their unnecessary digital-to-analog conversions

2 See http://www.hdmi.org/about/adopters_founders.asp

3 See <http://www.digital-cp.cott/list/>

4 HDMI, the HDMI logo and High-Definition Multimedia Interface are trademarks or registered trademarks of HDMI licensing LLC

5 With video and multi-channel audio combined into a single cable, the cost, complexity, and confusion of multiple cables currently used in A/V systems is reduced

6 HDMI technology has been designed to use standard copper cable construction at up to 15m

7 HDMI supports multiple audio formats, from standard stereo to multi-channel surround-sound. HDMI has the capacity to support Dolby 5.1 audio and high-resolution audio formats

8 HDMI provides the quality and functionality of a digital interface while also supporting uncompressed video formats in a simple, cost-effective manner

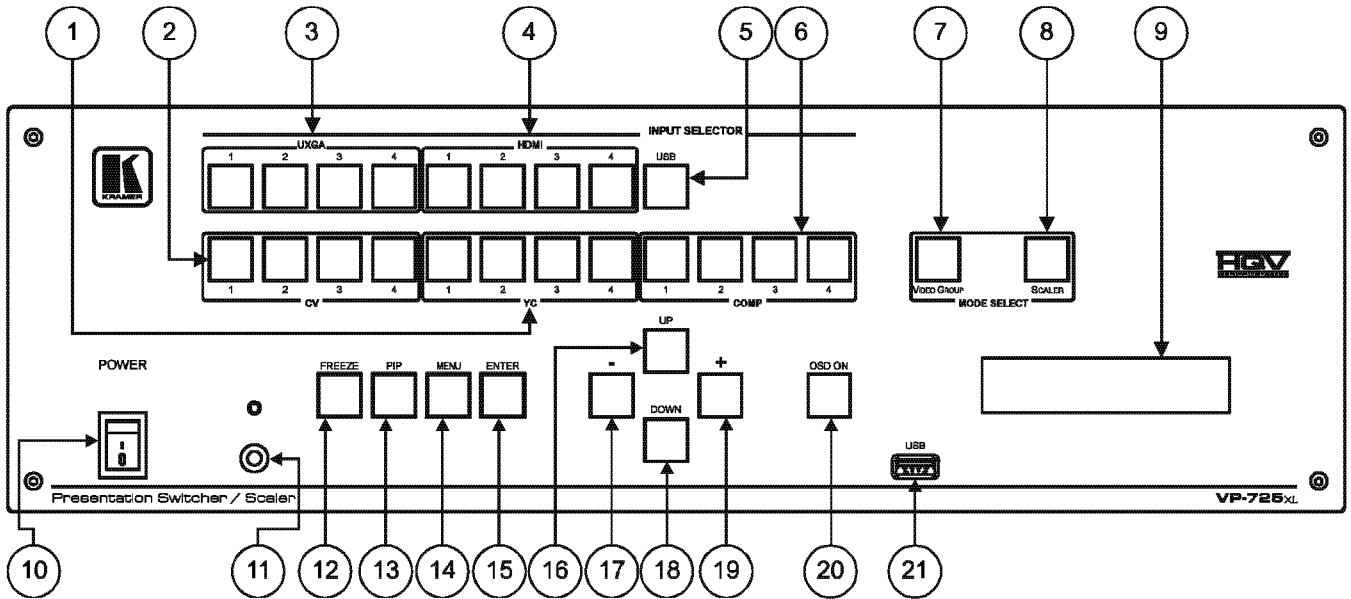

Figure 1: VP-725xl Presentation Switcher / Scaler Front Panel

Table 1: Front Panel VP-725xl Presentation Switcher / Scaler Features

#	Feature	Function
1	INPUT SELECTOR Buttons	YC Selects one of the s-Video (Y/C) sources (from 1 to 4)
2		CV Selects one of the CV sources (from 1 to 4)
3		UXGA Selects one of the UXGA sources (from 1 to 4)
4		HDMI Selects one of the HDMI sources (from 1 to 4)
5		USB Press to select the USB ¹ source
6		COMP Selects one of the component video sources (from 1 to 4)
7	MODE SELECT Buttons	VIDEO GROUP Select the Video group operation mode; within each group, select which input (from 1 to 4) to switch to the output. The selected input button within each group is illuminated (see section 7.1)
8		SCALER Select the Scaler operation mode; press an input button (1 of 20), to select the input to be scaled at the SCALED OUTPUTS. The selected input button illuminates (see section 7.1)
9	LCD Status Display	Displays the status
10	POWER Switch	Illuminated switch for turning the unit ON or OFF
11	IR Receiver / LED	Green when ON; red when OFF ²
12	FREEZE Button	Freezes the output video image ³
13	PIP Button	Selects the picture-in-picture function ^{3,4}
14	MENU Button	Displays the OSD Menu screen (or returns to the previous level in the OSD screen)
15	ENTER Button	Moves to the next level in the OSD screen ³ Press for about 3 seconds to lock/unlock the front panel buttons
16	UP Button	Moves up one step (in the same level) in the OSD screen ³
17	- Button	Decreases the range by one step ³
18	DOWN Button	Moves down one step (in the same level) in the OSD screen ³
19	+ Button	Increases the range by one step ³
20	OSD ON Button	Activates/deactivates access to the OSD Menu ^{3,5}
21	USB Connector	Connect to a USB drive to read JPEG files

Figure 2 and Table 2 define the rear panel of the **VP-725xl**:

1 JPEG files on a USB memory stick, up to a maximum size of 2048x1536

2 OFF in this case means that the outputs and the front-panel are disabled

3 Applicable to the Scaler outputs only

4 See section 7.2

5 The OSD ON front panel button is activated (illuminated) by default, and pressing the MENU front panel button (or the MENU key on the infrared remote control transmitter (see Figure 20)) displays the OSD Menu. To prevent OSD display, press the OSD ON front panel button (or the OSD key). The front panel button will no longer be illuminated, and the front panel LCD now operates independently of the OSD (when the OSD is OFF, the LCD is still operational)

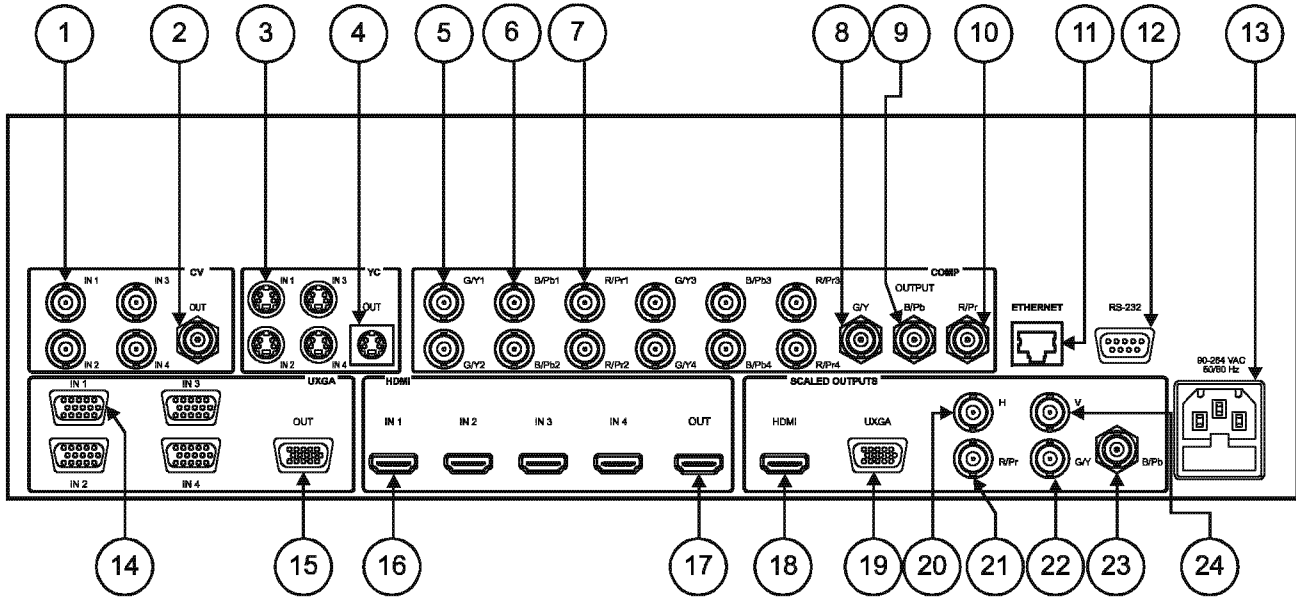

Figure 2: VP-725xl Presentation Switcher / Scaler Rear Panel

Table 2: Rear Panel VP-725xl Presentation Switcher / Scaler Features

#	Feature	Function	
1	<i>CV IN</i> BNC Connectors	Connects to the composite video sources (from 1 to 4)	
2	<i>CV OUT</i> BNC Connector	Connects to the composite video acceptor	
3	<i>YC IN</i> 4-pin Connectors	Connects to the s-Video (Y/C) sources (from 1 to 4)	
4	<i>YC OUT</i> 4-pin Connector	Connects to the s-Video (Y/C) acceptor	
5	<i>COMP</i> Input BNC Connector	<i>G/Y</i>	
6		<i>B/Pb</i>	
7		<i>R/Pr</i>	
8	<i>COMP</i> <i>OUTPUT</i> BNC Connector	<i>G/Y</i>	
9		<i>B/Pb</i>	
10		<i>R/Pr</i>	
11	<i>ETHERNET</i> port	Connects to your LAN ¹	
12	<i>RS-232</i> 9-pin D-sub Connector	Connects to a PC or Serial Controller	
13	Power Connector with <i>FUSE</i>	AC connector enabling power supply to the unit	
14	<i>UXGA IN</i> 15-pin HD Connectors	Connects to the UXGA (analog interface) graphics sources (from 1 to 4)	
15	<i>UXGA OUT</i> 15-pin HD Connector	Connects to the UXGA (analog interface) graphics acceptor	
16	<i>HDMI IN</i> Connectors	Connects to the HDMI sources (from 1 to 4)	
17	<i>HDMI OUT</i> Connector	Connects to the HDMI acceptor	
18	<i>SCALED OUTPUTS</i>	<i>HDMI</i> Connector	
19		<i>UXGA</i> 15-pin HD Connector	
20		<i>BNC</i> Connector	<i>H</i>
21			<i>R/Pr</i>
22			<i>G/Y</i>
23	<i>B/Pb</i>		
24	<i>V</i>		
		Connect to the component video or RGBHV acceptor	

¹ Local Area Network (that is, computers sharing a common communications line or wireless link, which often share a server within a defined geographic area)

5 Installing in a Rack

This section describes what to do before installing on a rack and how to rack mount.

Before Installing in a rack

Before installing in a rack, be sure that the environment is within the recommended range:	
Operating temperature range	+5° to +45° C (41° to 113° F)
Operating humidity range	10 to 90% RHL, non-condensing
Storage temperature range	-20° to +70° C (-4° to 158° F)
Storage humidity range	5 to 95% RHL, non-condensing



CAUTION!!

When installing on a 19" rack, avoid hazards by taking care that:

1. It is located within the recommended environmental conditions, as the operating ambient temperature of a closed or multi unit rack assembly may exceed the room ambient temperature.
2. Once rack mounted, enough air will still flow around the machine.
3. The machine is placed straight in the correct horizontal position.
4. You do not overload the circuit(s). When connecting the machine to the supply circuit, overloading the circuits might have a detrimental effect on overcurrent protection and supply wiring. Refer to the appropriate nameplate ratings for information. For example, for fuse replacement, see the value printed on the product label.
5. The machine is earthed (grounded) in a reliable way and is connected only to an electricity socket with grounding. Pay particular attention to situations where electricity is supplied indirectly (when the power cord is not plugged directly into the socket in the wall), for example, when using an extension cable or a power strip, and that you use only the power cord that is supplied with the machine.

How to Rack Mount

To rack-mount a machine:

1. Attach both ear brackets to the machine. To do so, remove the screws from each side of the machine (5 on each side), and replace those screws through the ear brackets.

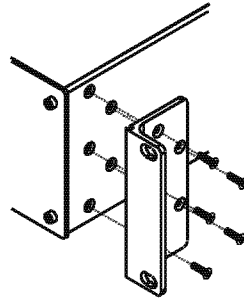

2. Place the ears of the machine against the rack rails, and insert the proper screws (not provided) through each of the five holes in the rack ears.

Note that:

- In some models, the front panel may feature built-in rack ears
- Detachable rack ears can be removed for desktop use
- Always mount the machine in the rack before you attach any cables or connect the machine to the power
- If you are using a Kramer rack adapter kit (for a machine that is not 19"), see the Rack Adapters user manual for installation instructions (you can download it at: <http://www.kramerelectronics.com>)

6 Connecting the VP-725xl Presentation Switcher / Scaler

This section describes how to connect the **VP-725xl**. In particular, how to connect the:

- **VP-725xl** rear panel (see section 6.1)
- Interlaced and progressive RGSB and RGSB inputs (see section 6.2)
- PC (see section 6.3)
- Ethernet port (see section 6.4)

Using the **VP-725xl** you can select any one of the 21 inputs and scale that input to up to three scaled outputs (at the identical resolution).

6.1 Connecting the VP-725xl

To connect the **VP-725xl**, connect the following¹ to the rear panel, as the example in Figure 3 illustrates:

1. Connect one or more of the following video sources:
 - Up to four UXGA graphics sources (for example, computers) to the 15-pin HD input connectors²
 - Up to four composite video sources (for example, DVD players) to the BNC input connectors
 - Up to four s-Video sources to the 4-pin input connectors (not illustrated in Figure 3)
 - Up to four component video³ (sometimes called YUV, or Y, B-Y, R-Y, or Y, Pb/Cb, Pr/Cr) sources or four RGB sources to the four sets of 3 BNC connectors, G/Y, B/Pb, and R/Pr.
 - Up to four HDMI sources (for example, DVD players) to the HDMI connectors
2. Connect the CV OUT BNC connector, and the UXGA OUT 15-pin HD connector to the respective video inputs on the projector.
3. Connect the HDMI connector to an LCD display.
4. Connect the COMP OUTPUT BNC connectors: G/Y, B/Pb, and R/Pr to the respective component video inputs on the LCD monitor.

1 Switch OFF the power on each device before connecting it to your VP-725XL. After connecting your VP-725XL, switch on its power and then switch on the power on each device

2 These connectors also accept interlaced and progressive RGSB and RGSB signals (see Table 3)

3 For example, an HDTV satellite receiver to COMP IN 1 and an RGB camera connected to COMP IN 4

5. Connect up to three SCALED OUTPUTS, as follows:
 - Connect the RGBHV connectors (G/Y, B/Pb, R/Pr, H, and V) to the RGBHV acceptor (for example, a projector)
 - Connect the HDMI connector to the HDMI acceptor (for example, an LCD display)
 - Connect the UXGA connector to the UXGA acceptor, for example, a monitor (not illustrated in Figure 3)
6. Connect the power cord¹ (not illustrated in Figure 3).
7. If required connect:
 - A PC (see section 6.3).
 - The Ethernet port (see section 6.4).

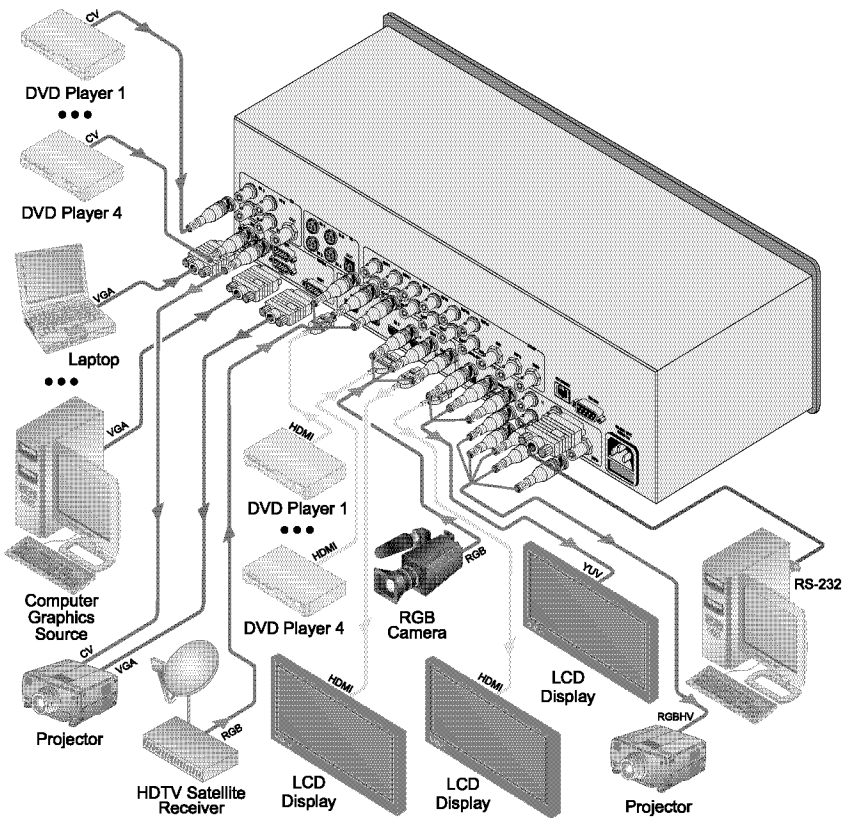

Figure 3: Connecting the VP-725xl Presentation Switcher / Scaler

¹ We recommend that you use only the power cord that is supplied with this machine

6.2 The RGBS and RGsB PINOUTS

Table 3 defines the input progressive¹ and interlaced² RGBS and RGsB pinouts:

Table 3: RGBS and RGsB PINOUTS

Input	Color Space	PINOUT
VGA	RGsB	Red to PIN 1 Green + sync, to PIN 2 Blue to PIN 3
	RGBS	Red to PIN 1 Green to PIN 2 Blue to PIN 3 Hs (H and V) to PIN 13
YUV	YPbPr	Green + sync to Y Blue to Pb Red to Pr

6.3 Connecting a PC

You can connect a PC (or other controller) to the **VP-725xl** via the RS-232 port for remote control, and for upgrading the firmware.

To connect a PC to a **VP-725xl** unit, using the Null-modem adapter provided with the machine (recommended):

- Connect the RS-232 9-pin D-sub rear panel port on the **VP-725xl** unit to the Null-modem adapter and connect the Null-modem adapter with a 9-wire flat cable to the RS-232 9-pin D-sub port on your PC

To connect a PC to a **VP-725xl** unit, without using a Null-modem adapter:

- Connect the RS-232 9-pin D-sub port on your PC to the RS-232 9-pin D-sub rear panel port on the **VP-725xl** unit, forming a cross-connection³, as Figure 4 illustrates

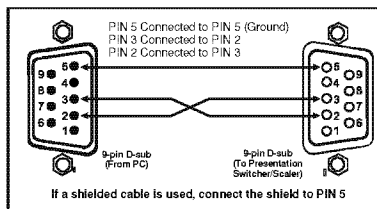

Figure 4: Connecting the PC

¹ A display mode in which all the horizontal lines of an image are displayed in a single frame (one field)

² A display mode in which a frame consists of two separate fields with the first field consisting of odd horizontal lines and the second field even horizontal lines

³ Also known as a Null-modem connection

6.4 Connecting the VP-725xl via the ETHERNET port

You can connect the **VP-725xl** via the Ethernet, using a crossover cable (see section 6.4.1) for direct connection to the PC or a straight through cable (see section 6.4.2) for connection via a network hub or network router.

See section 8.4 for Ethernet configuration.

6.4.1 Connecting the ETHERNET Port directly to a PC (Crossover Cable)

You can connect the Ethernet port of the **VP-725xl** to the Ethernet port on your PC, via a crossover cable with RJ-45 connectors.

This type of connection is recommended for identification of the factory default IP Address of the **VP-725xl** during the initial configuration

After connecting the Ethernet port, configure your network card as follows:

1. Right-click the My Network Places icon on your desktop.
2. Select Properties and right-click Local Area Connection Properties.
3. Select Properties.
The Local Area Connection Properties window appears.
4. Select **Internet Protocol (TCP/IP)** and click the Properties Button (see Figure 5).

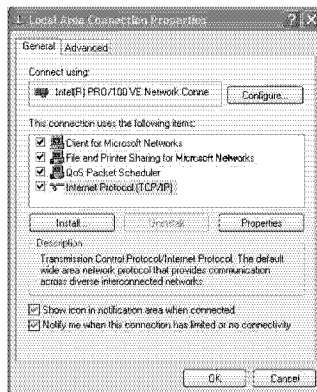

Figure 5: Local Area Connection Properties Window

5. Select **Use the following IP Address¹**, and fill in the details as shown in Figure 6.

¹ This IP address is compatible with the factory default IP address of the unit

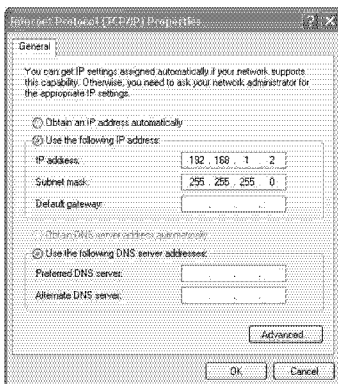

Figure 6: Internet Protocol (TCP/IP) Properties Window

6. Click OK.

6.4.2 Connecting the ETHERNET Port via a Network Hub (Straight-Through Cable)

You can connect the Ethernet port of the **VP-725xl** to the Ethernet port on a network hub or network router, via a straight-through cable with RJ-45 connectors.

7 Operating the Presentation Switcher / Scaler

The **VP-725xl** includes the following front panel buttons:

- A set of 21 INPUT SELECTOR buttons
- Video Group and Scaler Mode SELECT buttons
- A PIP button
- A FREEZE button
- A set of 7 OSD buttons (described in Table 1): OSD ON, MENU, ENTER, -, +, UP, and DOWN

This section describes how to:

- Switch an input to an output (see section 7.1)
- Use the PIP feature (see section 7.2)
- Lock and unlock the front panel buttons (see section 7.3)
- Freeze the image (see section 7.4)
- Display a blank screen (see section 7.5)

7.1 Switching an Input in the Video Group Mode/Scaler Mode

The **VP-725xl** can operate in two different modes:

- The Video Group mode, in which you can switch an input (from 1 to 4) to an output in each of the five Video Groups: composite video, s-Video, component video (RGB or YPbPr), HDMI and UXGA
- The Scaler mode, in which you can select one of the 21 input buttons to switch to the scaled outputs

When the **VP-725xl** is in use, both modes operate simultaneously, as well as independently. That is, the Scaler output is available even when switching in the Video Group mode, and visa-versa.

7.2 Understanding the PIP Feature¹

The Picture-in-Picture inserter (PIP) is used for the simultaneous display of video and graphic sources, and lets you display:

- An inserted video source² PIP over a graphic source³
- An inserted graphic source³ PIP over a video source²

When selecting a PIP source, the Presentation Switcher / Scaler automatically recognizes and can display the selected graphic PIP source on any video source⁴ or the selected video source on any graphic⁴ source, compliant to Table 4.

Table 4: PIP Source Appearance Availability

	PIP Source				
	VIDEO		GRAPHIC		
Main Source	CV	YC	VGA	HDMI	COMP ⁵
CV	No	No	Yes	Yes	Yes
YC	No	No	Yes	Yes	Yes
VGA	Yes	Yes	No	No	No
HDMI	Yes	Yes	No	No	No
COMP	Yes	Yes	No	No	No
USB	Yes	Yes	No	No	No

¹ See section 8.1.4

² That is, composite, s-Video

³ That is, HDMI or UXGA or component

⁴ Even if the input signal is not connected. In this case the PIP appears over a blank screen

⁵ In this machine COMP is considered a graphic source even in the case where it is at video resolutions

Activate the PIP Feature by:

- Pressing the PIP front panel button
- Switching on the PIP functionality via the OSD Menu (see section 8.1.4)
- Pressing the PIP key on the remote control transmitter (see section 8.3)

Toggle between the PIP and screen source by:

- Pressing the SWAP key on the remote control transmitter (see section 8.3)

Resize the PIP by:

- Using the OSD menu (see section 8.1.4)
- Pressing the PIP Size key on the remote control transmitter (see section 8.3)

Move the position of the PIP by:

- Using the OSD menu (see section 8.1.4)

Choose a new PIP source by:

- Pressing the "PIP Source" button on the remote control transmitter followed by the button of the desired PIP input
- Pressing and holding down the PIP front panel button and then pressing the button of the desired PIP input (while the PIP button is still pressed)

7.3 Locking and Unlocking the Front Panel

To prevent accidental changes to settings or unauthorized tampering with the front panel, you can lock the front panel.

To lock the front panel, press and hold the ENTER front panel button¹ for about 3 seconds.

The front panel buttons are locked² (except for the ENTER button on the front panel).

The LCD displays: Keypad Lock On.

To unlock the front panel buttons (releasing the protection mechanism), press and hold the ENTER front panel button for about 3 seconds.

¹ Does not apply to the ENTER key on the infrared remote control transmitter

² However, operation via the infrared remote transmitter or RS-232 serial commands (remote controller or PC) and/or ETHERNET is still available

7.4 Freezing the Image

To freeze the image, press the Freeze key on the infrared remote control transmitter (see Figure 20) or the FREEZE front panel button.

The image freezes and the FREEZE front panel button illuminates.

The LCD displays: Freeze.

You can define the function of the FREEZE button (Freeze and mute, freeze or mute) via the OSD menu (see Table 14).

7.5 Displaying a Blank Screen

To display a blank screen, press the Blank key on the infrared remote control transmitter (see Figure 20). You can set the blank color to blue or black and also define the function of the Blank key¹ via the OSD menu (see Table 14).

¹ Blank and mute, blank or mute

8 Configuring and Controlling the VP-725xl

This section describes how to configure and control the **VP-725xl** via the:

- OSD menu (see section 8.1)
- LCD display (see section 8.2)
- Infrared remote control transmitter (see section 8.3)

You can also control the **VP-725xl** via the Ethernet (see section 8.4)

8.1 Configuring the VP-725xl via the OSD MENU Screens

The OSD superimposes a menu on the screen from which you can configure and control each input signal on your **VP-725xl**, using the MENU, ENTER, -, +, UP and DOWN OSD buttons on the front panel and the remote transmitter.

To use the OSD menus:

1. Select the desired input signal.
2. Use the menu buttons as follows:
 - Press the MENU front panel ON button or the MENU key on the infrared remote control transmitter (see section 8.3) to display the main MENU screen¹, which displays eight interactive icons² (see Figure 7)
 - Press the MENU front panel OSD button or the MENU key on the infrared remote control transmitter to move to the previous level in the OSD screen (Esc)
 - Press the UP or DOWN buttons to select menu icons and then press ENTER
 - Use + and – buttons to increase and decrease the (numerical) rate respectively

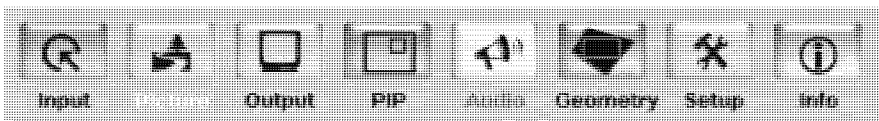

Figure 7: MENU Items

¹ Each icon represents a Level 1 function. In addition to Level 1, the OSD structure includes Level 2 (a subset of level 1), Level 3 (a subset of level 2) and a numerical range

² The Audio menu is not applicable for the VP-725xl

8.1.1 The Input Screen

Figure 8 and Table 5 define the Input screen.

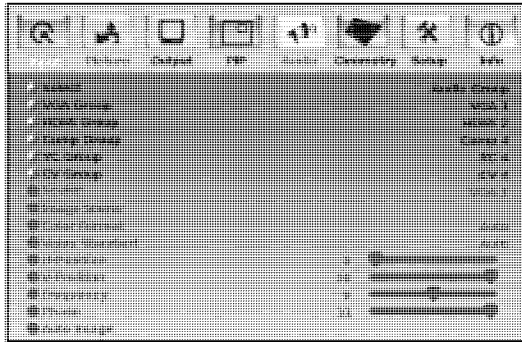

Figure 8: Input Screen

Table 5: Input Screen Functions

Setting	Function	Selection/Range	Default
Select	Select the group	Video Group, Scaler	Scaler
VGA Group	Select the VGA input ¹	From 1 to 4	VGA 1
HDMI Group	Select the HDMI input ¹	From 1 to 4	HDMI 1
Comp Group	Select the Comp input ¹	From 1 to 4	Comp 1
YC Group	Select the YC input ¹	From 1 to 4	YC 1
CV Group	Select the CV input ¹	From 1 to 4	CV 1
Scaler	Select the source to scale (in the Scaler operation mode)	From VGA 1 to VGA 4; from HDMI 1 to HDMI 4; from COMP 1 to COMP 4; from YC 1 to YC 4; from CV 1 to CV 4, and USB	VGA 1
Image Name	Shows the file name ² that is displayed when the USB port is connected		
Color Format	Select the color format	Auto, RGB or YUV	Auto
Video Standard	Select the video standard	Auto, NTSC, PAL, PAL-M, PAL-N, NTSC 4.43, SECAM or PAL-60	
H-Position	Set the horizontal position ³	The range changes according to the input mode	Auto
V-Position	Set the vertical position	The range changes according to the input mode	
Frequency	Adjust the frequency ⁴	The range changes according to the input mode	
Phase	Adjust the phase	0 to 31	0
Auto image	Assesses the image and improves the quality accordingly, by automatically adjusting the phase, frequency and position. Upon completion, the relevant OSD values are updated (Hpos, Vpos, Phase and Frequency)		

¹ In the Video Group operation mode

² Supports JPEG format only. The JPEG file should not exceed a resolution of 2048x1536. If the image file is not within the definition a blank screen appears and the machine displays the message: "File Error"

³ For UXGA and component video inputs

⁴ For UXGA inputs

8.1.2 The Picture Screen

Figure 9 and Table 6 define the Picture screen.

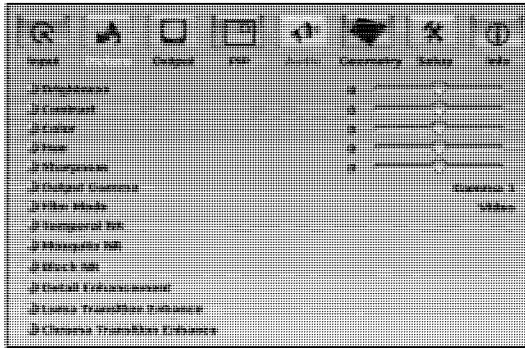

Figure 9: Picture Screen

Table 6: Picture Screen Functions

Setting	Function	Selection/Range	Default
Brightness	Adjust the brightness	-50 to 50	0
Contrast	Adjust the contrast	-50 to 50	0
Color	Adjust the color	-50 to 50	0
Hue	Adjust the hue	-180 to 180	0
Sharpness	Adjust the sharpness	-50 to 50	0
Output Gamma	Adjust the gamma	Gamma 1 to Gamma 5	Gamma 1
Film Mode	Set the film mode	Auto, Video, Film	Auto
Temporal NR ¹	Set the temporal noise reduction level	Off, Low, Medium, High	High
Mosquito NR ¹	Set the Mosquito noise reduction level	Off, Low, Medium, High	Low
Block NR ¹	Set the block noise reduction level	Off, On	Off
Detail Enhancement ¹	Set the detail enhancement	Off, Low, Medium, High	Medium
Luma Transition Enhance ¹	Set the luminance transition enhance level	Off, Low, High	Low
Chroma Transition Enhance ¹	Set the chrominance transition enhance level	Off, Low, High	Low

¹ You do not have to press ENTER after selecting the desired parameter to change it

8.1.3 The Output Screen

Figure 10 and Table 7 define the Output screen.

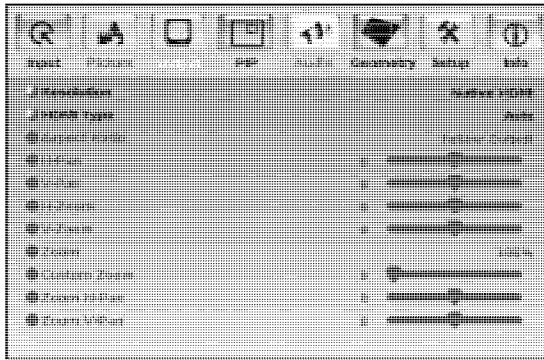

Figure 10: Output Screen

Table 7: Output Screen Functions

Setting	Function	Selection/Range	Default
Resolution	Set the resolution ¹	Native HDMI ² , 640x480x60Hz, 640x480x75Hz, 800x600x50Hz, 800x600x60Hz, 800x600x75Hz, 1024x768x50Hz, 1024x768x60Hz, 1024x768x75Hz, 1280x768x50Hz, 1280x768x60Hz, 1280x720x60Hz, 1280x800x60Hz, 1280x1024x50Hz, 1280x1024x60Hz, 1280x1024x75Hz, 1366x768x50Hz, 1366x768x60Hz, 1400x1050x50Hz, 1400x1050x60Hz, 1600x1200x50Hz, 1600x1200x60Hz, 1680x1050x60Hz, 1920x1080x60Hz, 1920x1200x60Hz, 480px60Hz, 576px60Hz, 720px50Hz, 720px60Hz, 1080ix50Hz, 1080ix60Hz, 1080px50Hz, 1080px60Hz or Custom (from 1 to 4) ³	If Native HDMI is not available, the default is 1024x768@60Hz
HDMI Type	Set the HDMI type	Auto, HDMI, DVI	auto
Aspect Ratio	Set the aspect ratio	Best Fit ⁴ , Letterbox, Follow Output ⁵ , Virtual Wide, Follow Input ⁶ , Custom	Standard
H-Pan ⁷	Horizontal pan	-16 to 16	0
V-Pan ⁷	Vertical pan	-16 to 16	0
H-Zoom ⁷	Horizontal zoom	-8 to 8	0
V-Zoom ⁷	Vertical zoom	-8 to 8	0
Zoom	Set the Zoom ¹	100%, 150%, 200%, 225%, 250%, 275%, 300%, 325%, 350%, 375%, 400%, Custom	100%

1 Any change in the resolution must be confirmed via the count-down message that appears on the screen

2 If the Native HDMI is 1920x1080x60, the preferred mode will be defined as 1920x1080x60 (CEA-861)

3 If the custom resolution is set to be the same as the default resolution, the scaler refers to the default resolution

4 The best possible compromise between the input and the output aspect ratios

5 Scales the picture to fill the entire output screen

6 Shows the picture without scaling it (pixel-to-pixel mapping)

7 Available when selecting Custom aspect ratio

Setting	Function	Selection/Range	Default
Custom Zoom ²	Set the Zoom	From 0 to 32 (this range is equivalent to 100% to 400%)	
Zoom H-Pan		-16 to 16	0
Zoom V-Pan		-16 to 16	0

8.1.4 The PIP Screen

Figure 11 and Table 8 define the PIP screen.

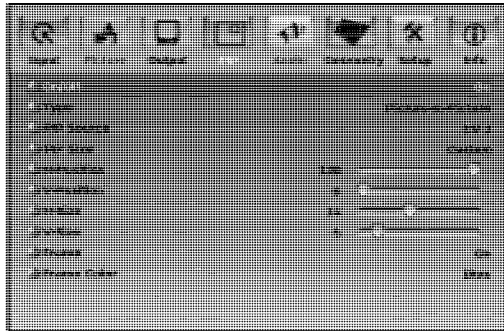

Figure 11: PIP Screen

Table 8: PIP Screen Functions

Setting	Function	Selection/Range	Default
On/Off	Activate/deactivate the PIP feature ³	On/Off	Off
Type	Select the PIP type	Picture-In-Picture, Picture + Picture ⁴ or Split	Picture-In-Picture
PIP Source	Select the PIP source ⁵	See Table 4	
PIP Size	Select the PIP size	1/25, 1/16, 1/9, 1/4, or Custom	1/4
H-Position	Set the horizontal position of the PIP on the display	0 to 128	3
V-Position	Set the vertical position of the PIP on the display	0 to 128	0
H-Size	Set custom size ⁵	1 to 255	14
V-Size	Set custom size ⁶	1 to 255	5
Frame	Turn the PIP frame on or off	On/Off	On
Frame Color	Select the color of the PIP frame	Red, Green or Blue	Blue

1 The zoom feature is disabled when the aspect ratio is set to custom or when the PIP feature is on

2 This function is available after setting the Zoom to custom

3 When PIP is activated and that input is not connected, the PIP window will appear black. If the zoom function is ON, the OSD prompts "cancel zoom?"

4 Maintains the aspect ratio

5 When changing the PIP source, the display fades through black

6 The actual range depends upon the input resolution

8.1.5 The Geometry Screen

Figure 12 and Table 9 define the Geometry screen, allowing the user flexibility in positioning his projector relative to the screening surface.

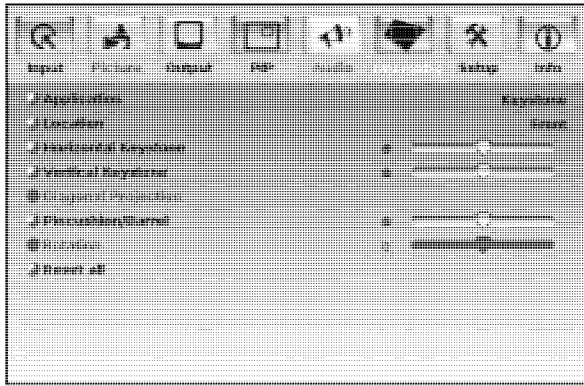

Figure 12: Geometry Screen

Table 9: Geometry Screen Functions

Setting	Function	Selection/Range	Default
Application	Select the output application	Keystone, Anyplace or Rotation	Keystone
Location	Select the location of the display	Front, Ceiling, Rear or Rear ceiling	Front
Horizontal Keystone	Adjust the horizontal keystone ¹	-40 to 40	0
Vertical Keystone	Adjust the vertical keystone ²	-30 to 30	0
Diagonal Projection	Move the location of each corner of the display separately ³	Top Left, Top Right, Bottom Left, Bottom Right or Reset (to reset diagonal projections settings)	Top Left
Pincushion/Barrel	Adjust the pincushion or barrel appearance of the screen ⁴	-20 to 20	0
Rotation	Rotate the display clockwise or counterclockwise (in 1° increments)	-180 to 180	0
Reset all	Resets the geometry settings to their default values		

1 If the projector is located at an angle to the left or right of the screen

2 If the projector is located at an angle above or below the screen

3 Horizontally and vertically

4 For projection onto curved surfaces

Table 10 defines the settings available for each application:

Table 10: Available Settings for Each Application

Application	Available Settings
Keystone	Location, horizontal keystone, vertical keystone, pincushion/barrel and Reset all
Anyplace	Location, Diagonal Projection and Reset all
Rotation	Location, pincushion/barrel, Rotation and Reset all

8.1.6 The Setup Screen

Figure 13 and Table 11 define the Setup screen.

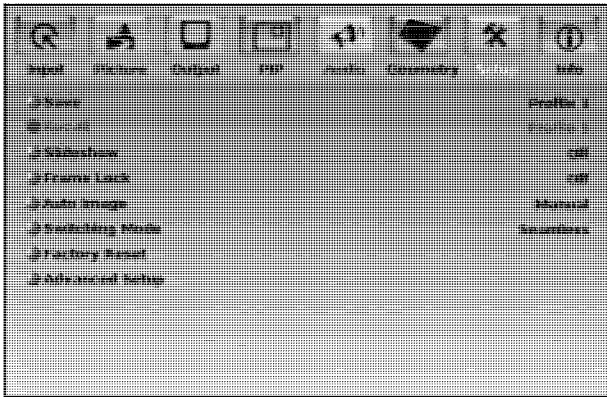

Figure 13: Setup Screen

Table 11: Setup Screen Functions

Setting	Function	Selection/Range	Default
Save	Save a profile	From Profile 1 to Profile 8	
Recall	Recall a profile	From Profile 1 to Profile 8	
Slideshow	Set speed for slide show (see section 8.1.7)	Min, Low, Mid, Long, Max, Off	Off
Frame Lock	Locks the vertical refresh rate of the output to that of the input ¹	On/Off	Off
Auto Image	Automatically adjust and align the picture each time one of the UXGA inputs is selected or if the UXGA input resolution has changed	Manual, Auto	Manual

¹ When frame-locked, the output frame-rate is locked to the input frame-rate. It is not always possible to frame-lock the output to the input – for example, if the input is from a 75Hz source and 1080p is selected as the output resolution, there is no defined standard for 1080p@75Hz (and no projector would recognize this!). Note that – by definition – in the case that frame-lock is selected, the switching between inputs cannot be not seamless. This is because the output will synchronize to the input each time a new source is selected

Setting	Function	Selection/Range	Default
Switching Mode	Select seamless switching (fade-through-Black) or fast switching which is faster but may cause glitches on the output (applies only when switching between analog inputs)	Seamless, Fast	Seamless
Factory Reset	Reset your VP-725xl to its preset default settings	Confirm, Yes, No	
Advanced Setup	Open the advanced setups (see Figure 14)	Mode Set (see Table 12) OSD (see Table 13) Misc. (see Table 14) Input (see Table 15) Output (see Table 16)	

8.1.7 The Slideshow Feature

The **VP-725xl** lets you run a slideshow via the USB input and set the slideshow speed via the slideshow feature.

To prepare a slideshow:

1. Load the slideshow JPEG¹ images to a USB memory stick.
The slides will appear in alphabetical order.
2. Open the Setup menu and set the desired speed in the slideshow item and then close the menu.
3. Connect the Memory stick to the USB connector on the front panel.
4. Select the USB INPUT button on the front panel.
The slideshow begins at the set speed.

You have to set the slideshow parameters before you run the slideshow

You can control the slide show by pressing the:

- FREEZE button to pause
- USB button to play and stop the slideshow
- Up button to go to the previous slide
- Down button to go to the next slide

¹ JPEG files are recognized up to 2048x1536

8.1.7.1 The Advanced Setup Screen

Figure 14 to Figure 17, and Table 13 to Table 16 define the Advanced Setup screens.

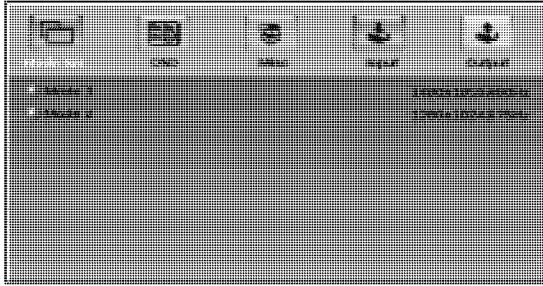

Figure 14: Advanced Setup Screen

The Mode Set functions define the desired working resolution and refresh rate when the system cannot distinguish between similar resolutions and refresh rate values (see Table 12).

Table 12: Mode Set Functions

Setting	Function	Selection/Range	Default
Mode 1	Set mode 1	1400x1050x60Hz 1680x1050x60Hz	1400x1050x60Hz
Mode 2	Set mode 2	1280x1024x75Hz 1280x1024x76Hz	1280x1024x75Hz

Table 13: OSD Functions

Setting	Function	Selection/Range	Default
Menu Position	Set the location of the OSD menu	Center, Top Left, Top Right Bottom Left, Bottom Right	Top Right
Time Out (sec)	Set the OSD menu timeout	5, 10, 20, 30, 60, 90 or Off	30

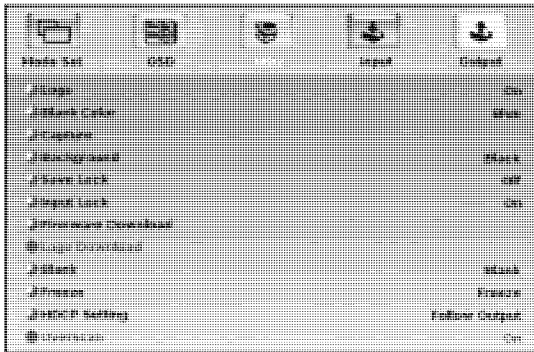

Figure 15: Misc Setup Screen

Table 14: Misc Functions

Setting	Function	Selection/Range	Default
Logo	Choose ON for the start up logo to appear on the screen OFF for it not to appear Set to Custom to download a custom Logo ¹ (Flash ROM)	On, Off or Custom	Kramer Logo (On)
Blank Color	Set the blank color (the color that appears on the screen when the blank button is pressed)	Black or Blue	Blue
Capture	Press to capture the desired image input ² to Flash ROM for using as a logo or as the background	Prompts "Capture" The captured image is saved as the "Custom" background and/or logo	
Background	Set the background screen color	Blue, Black, Custom ³	Default
Save Lock	Set the Save Lock option to ON to save the lock status when the machine is powered down	On/Off	Off
Input Lock	Set the Input Lock to OFF so you can still use the SOURCE buttons on the front panel even when the lock button is on	On/Off	Off
Firmware Download	Download the firmware via the USB connection	Select the correct file from the memory stick and Confirm	
Logo Download	Download a new logo via the USB connection		
Blank	N/A		
Freeze	N/A		
HDCP Setting	Define whether the HDCP will follow the input or the output	Follow Input ⁴ , Follow Output ⁵	Follow output
Overscan	Allows stretching of the outputted picture	On, Off	Off

1 Obtained via the Capture function or downloaded via USB

2 The capture image size may not exceed 1280x1024

3 Obtained via the Capture function

4 When Follow Input is selected, the Scaler changes its HDCP output setting (for the HDMI output) according to the HDCP of the input. This option is recommended when the HDMI Scaler output is connected to a splitter/switcher (in this mode, switching may not be glitch-free)

5 When Follow Output is selected, the Scaler matches its HDCP output to the HDCP setting of the HDMI acceptor to which it is connected. This ensures smooth switching, regardless of the input

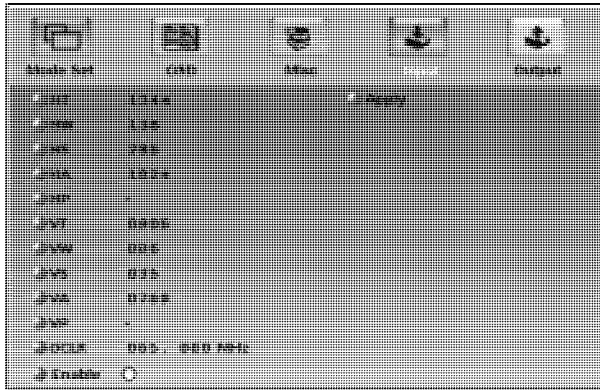

Figure 16: Input Setup Screen

Table 15: Input Functions

Setting	Function	Range	Default
HT	Horizontal Total		1344
HW	Horizontal sync pulse width		136
HS	Horizontal active start point		296
HA	Horizontal active region		1024
HP	Horizontal polarity		
VT	Vertical Total		806
VW	Vertical sync pulse width		6
VS	Vertical active start point		35
VA	Vertical active region		768
VP	Vertical polarity		
OCLK	Output clock		65
Enable			off
Apply	Press to apply settings		N/A

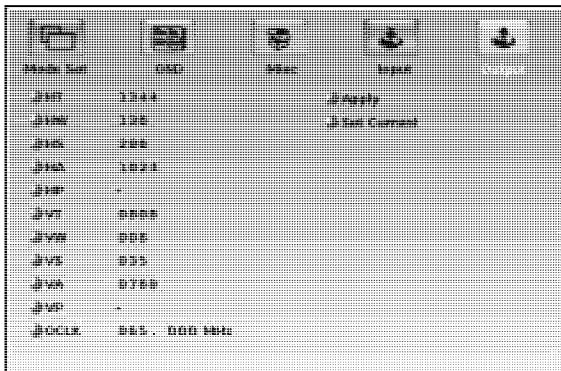

Figure 17: Output Setup Screen

Table 16: Output Functions

Setting	Function	Range	Default
HT	Horizontal total		1344
HW	Horizontal sync pulse width		136
HS	Horizontal active start point		296
HA	Horizontal active region		1024
HP	Horizontal polarity		
VT	Vertical total		806
VW	Vertical sync pulse width		6
VS	Vertical active start point		35
VA	Vertical active region		768
VP	Vertical polarity		
OCLK	Output clock		65
Apply	Press to apply the settings		
Set Current	Import the values of the currently selected output resolution into the User Mode Setting		N/A

8.1.8 Verifying Configuration Details via the Info Screen

From the Information screen (see Figure 18), you can verify the scaler source, the master audio source, the PIP source, the video group source, the output resolution, the SYNC mode (Frame lock or Free run), as well as the firmware version number:

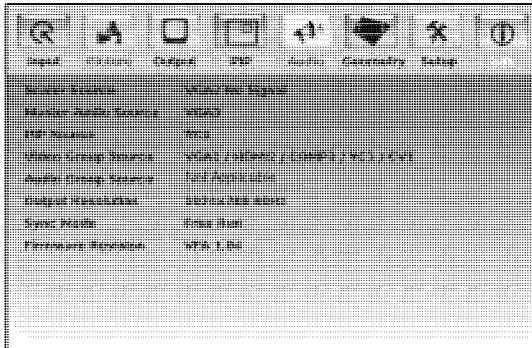

Figure 18: Information Screen

8.2 Operating via the LCD Display

You can control the **VP-725xl** from the front panel high contrast LCD Display. You can operate the **VP-725xl** via the LCD Display, using the:

- Front panel OSD buttons: *MENU*, *ENTER*, *-*, *+*, *UP* and *DOWN*
- Infrared remote control transmitter (see section 8.3) keys: *MENU*, and the navigation keys

For example, to set¹ the Keystone to 6 via the LCD Display, using the front panel buttons, do the following:

1. Turn the **VP-725xl** unit ON, and press the OSD ON button (if selected) to deselect it.
2. Press the appropriate front panel OSD buttons (as defined in Figure 19).

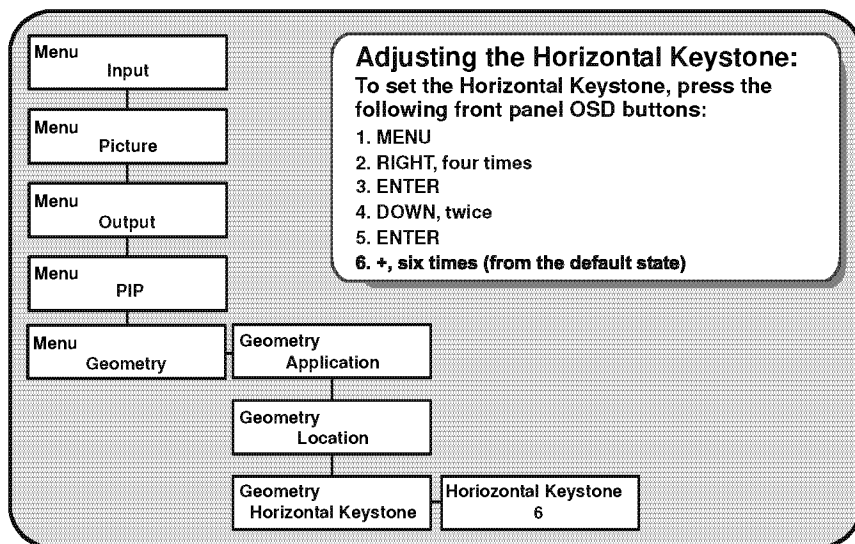

Figure 19: Example of how to use the LCD Display

8.3 Operating via the Infrared Remote Control Transmitter

You can control the **VP-725xl** remotely, from the infrared remote control transmitter (that has a range of up to 15 meters and is powered by two AAA size 1.5V DC batteries), as defined in Figure 20 and Table 17:

¹ To keep the picture rectangular. Section 8.1.5 illustrates how to adjust the Keystone via the OSD Menu

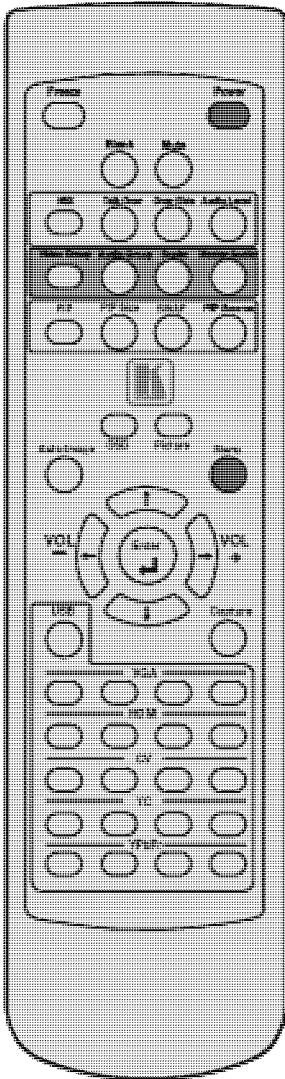

Figure 20: Infrared Remote Control Transmitter

Table 17: Infrared Remote Control Transmitter Functions

Key	Function
Freeze	Pauses the output video
Power	Cycles power
Blank	Toggles between a blank screen (blue or black screen) and the display
Mute	N/A
MIX	N/A
Talk Over	N/A
Over Ride	N/A
Audio Level	N/A
Video Group	Select the Video group operation mode
Audio Group	N/A
Scaler	Select the Scaler operation mode
Master Audio	N/A
PIP	Toggles the picture-in-picture function and illuminates/turns off the PIP button
PIP Size	Toggles the PIP size
SWAP	Toggles between the PIP content and the parent screen content
PIP Source	Selects the PIP source ¹
Auto Image	Assesses the image and improves the quality accordingly, by automatically adjusting the phase, frequency and position
OSD	Activates/deactivates access to the OSD Menu
Picture	Open the Picture menu ²
Menu	Opens the Main menu ²
Navigation arrows	Allows maneuvering within an OSD screen (left, right, up and down, as well as the Enter arrow at the center)
USB	select the USB ³ source
Capture	Capture an image to place as a logo or background
VGA	selects the VGA (UXGA) source (from 1 to 4)
HDMI	selects the HDMI source (from 1 to 4)
CV	selects the CV source (from 1 to 4)
YC	selects the YC source (from 1 to 4)
YPbPr	selects the YPbPr (COMP) source (from 1 to 4)

1 Press the PIP Source key and then an input key

2 Opens the menu on the LCD display and if the OSD button illuminates, will open the relevant OSD

3 JPEG files on a USB memory stick

8.4 Operating via ETHERNET/Serial Port

To control your **VP-725xl** via the Ethernet/Serial Port:

- Connect the ETHERNET port of the **VP-725xl** to the Ethernet port of your PC¹
- Download the Ethernet Application from our Web site on <http://www.kramerelectronics.com>
- Install and configure the Ethernet Application

9 Using Text Overlay

The text overlay feature is accessed via the Application Program (AP)².

Running this AP with the PC connected to the **VP-725xl** lets you display text over the screen, with features including text color and speed, transparency, text position and repetition. Current text overlay settings can be saved and loaded to the AP.

Figure 21 and Table 18 define the Text Overlay Application Screen:

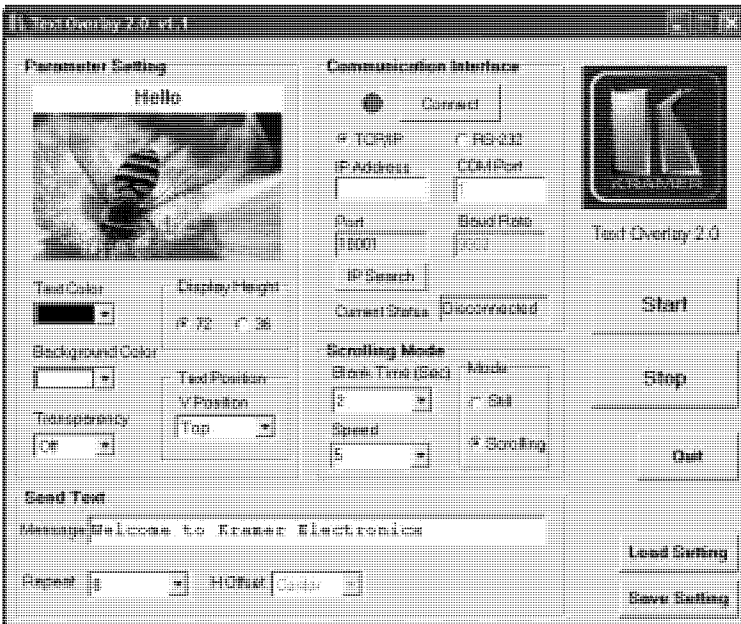

Figure 21: TextOverlay Application Screen

¹ Or connect the serial port of your VP-725xl to the serial port of your PC (see section 6.3)

² You can download the latest software from our Web site: <http://www.kramerelectronics.com>

Table 18: Features and Functions of the TextOverlay Application

Feature	Function
Parameter Setting Area	
<i>Text Color</i> Dropdown Box	Select the Text color
<i>Background Color</i> Dropdown Box	Set the text background color
<i>Transparency</i> Dropdown Box	Select On for a transparent background or Off for a non-transparent background
<i>Display Height</i> Check Box	Set the thickness of the background stripe (72 or 36)
<i>Text Position – V-Position</i>	Set the vertical position of the text background on the display screen (Top, Center or Bottom)
Communication Interface Area	
<i>Connect/Disconnect</i>	Connect the machine or disconnect
<i>TCP/IP</i> Check box	When selected, set the <i>IP Address</i> ¹ and <i>Port</i> to connect via Ethernet ²
<i>RS-232</i> Check box	When selected, set the <i>COM port</i> and <i>Baud Rate</i> (9600) to connect via the RS-232 connector ²
Scrolling Mode Area	
<i>Blank Time (Sec)</i> Dropdown Box	Set the blank delay time (from 1 to 5)
<i>Speed</i> Dropdown Box	Set the speed at which the text moves on the display (from 1 to 5)
<i>Mode</i>	Set to <i>Still</i> (fixed text) or <i>Scrolling</i> (text moves across the display)
Send Text Area	
<i>Message</i>	Type the desired text in the <i>Message</i> box
<i>Repeat</i> Dropdown Box	Set the number of times that the text message will scroll across the screen ³ (1 to 20), or set to <i>Forever</i> to repeat the text message continuously
<i>H-Offset</i> Dropdown Box	After selecting the <i>Static</i> mode, use the <i>H-Offset</i> box to select the horizontal position of the text (Left Center or Right)
<i>Start</i> Button	Click to display the text on screen
<i>Stop</i> Button	Click to stop scrolling on screen
<i>Quit</i> Button	Click to quit the program
<i>Load Setting</i> Button	Click to load a previously saved setting
<i>Save Setting</i> Button	Click to save the current setting

1 Or search the IP address

2 You have to select the connection type before connecting the software to the machine

3 For example, set to 2 to repeat the text twice

10 Technical Specifications

Table 19 includes the technical specifications:

Table 19: Technical Specifications¹ of the VP-725xl Presentation Switcher / Scaler

INPUTS:	4 x CV 1Vpp/75Ω on BNC connectors; 4 x YC 1Vpp (Y); 0.3Vpp (C)/75Ω on 4-pin connectors; 4 x Component (Y/G, Pb/B, Pr/R or RGsB ²) on BNC connectors; 4 x VGA (VGA through UXGA, RGBS or RGsB ²) on 15-pin HD connectors; 4 x HDMI on HDMI connectors
GROUP OUTPUTS:	1x CV 1Vpp/75Ω on a BNC connector; 1 x YC 1Vpp (Y); 0.3Vpp (C)/75Ω on a 4-pin connector; 1 x Component (Y/G, Pb/B, Pr/R) on BNC connectors; 1 x VGA (VGA through UXGA) on a 15-pin HD connector; 1 x HDMI on an HDMI connector
SCALED OUTPUTS:	1x UXGA a 15-pin HD connector; 1 x RGBHV / YPbPr on BNC connectors; 1 x HDMI on an HDMI connector
OUTPUT RESOLUTIONS:	Native HDMI ³ , 640x480x60Hz, 640x480x75Hz, 800x600x50Hz, 800x600x60Hz, 800x600x75Hz, 1024x768x50Hz, 1024x768x60Hz, 1024x768x75Hz, 1280x768x50Hz, 1280x768x60Hz, 1280x720x60Hz, 1280x800x60Hz, 1280x1024x50Hz, 1280x1024x60Hz, 1280x1024x75Hz, 1366x768x50Hz, 1366x768x60Hz, 1400x1050x50Hz, 1400x1050x60Hz, 1600x1200x50Hz, 1600x1200x60Hz, 1680x1050x60Hz, 1920x1080@60Hz, 1920x1200@60Hz ⁴ , 480px60Hz, 576px60Hz, 720px50Hz, 720px60Hz, 1080ix50Hz, 1080i 60Hz, 1080px50Hz, 1080px60Hz or Custom
CONTROL:	Front panel buttons, IR remote control, RS-232, Ethernet; with OSD and front panel LCD
ADDITIONAL CONTROLS:	Freeze, zoom, different selectable vertical refresh rates, output image scaling, Picture-In-Picture, aspect ratio change, Geometry settings, text overlay, and so on
POWER SOURCE:	100-240 VAC, 50/60Hz 38VA
DIMENSIONS:	19" x 7" x 3U W, D, H, rack mountable
WEIGHT:	5.5kg (12.2lbs) approx.
ACCESSORIES:	IR remote control, power cord

¹ Specifications are subject to change without notice

² Progressive and interlaced

³ If the Native HDMI is 1920x1080x60, the preferred mode will be defined as 1920x1080x60(CEA-861)

⁴ Reduced blanking

Technical Specifications

Table 20: Technical Specifications of the RGBHV / RGBS (PC) / RGB (PC) Input Signal¹

Resolution	Vertical Frequency (Hz)	Notes	Resolution	Vertical Frequency (Hz)	Notes
640x480 (480p)	60	VESA	1152x870	75	Mac21
640x480	67	Mac13	1152x900	66	Sun
640x480	72	VESA	1152x900	76	Sun
640x480	75	VESA	1280x720	60	VESA
640x480	85	VESA	1280x800	60	VESA
720x400	70		1280x960	60	VESA
720x400	85	VESA	1280x960	85	VESA
800x600	56	VESA	1280x768	60	VESA
800x600	60	VESA	1280x1024	60	VESA
800x600	72	VESA	1280x1024	75	VESA
800x600	75	VESA	1280x1024	76	Sun
800x600	85	VESA	1280x1024	85	VESA
832x624	75	Mac16	1366x768	60	VESA
1024x768	60	VESA	1440x900	60	VESA
1024x768	70	VESA	1400x1050	60	VESA
1024x768	75	VESA	1400x1050	75	VESA
1024x768	75	Mac19	1600x1200	60	VESA
1024x768	85	VESA	1680x1050	60	VESA
1024x800	84	Sun	1920x1080	60	VESA
1152x864	75	VESA	1920x1200	60	VESA

Table 21: Technical Specifications of the Y/C, Video Signal

Standard	NTSC, NTSC4.43, PAL, PAL-M, PAL-N, SECAM, PAL-60
-----------------	--

Table 22: Technical Specifications of the HDMI input Signal (for RGB or YUV Colorspace)

Resolution	Vertical Frequency (Hz)	Remark
1080i	60	YPbPr
1080i	50	YPbPr
1080p	60	YPbPr
1080p	50	YPbPr
1080P	24fps	YPbPr
720p	60	YPbPr
720p	50	YPbPr
480i	60	YPbPr
480p	60	YPbPr
576i	50	YPbPr
576p	50	YPbPr

¹ For the most updated resolution list, go to our Web site at <http://www.kramerelectronics.com>

Technical Specifications

Table 23: Technical Specifications of the Component Input Signal

Resolution	Vertical Frequency (Hz)	Remark
1080i	60	YPbPr
1080i	50	YPbPr
1080p	60	YPbPr
1080p	50	YPbPr
720p	60	YPbPr
720p	50	YPbPr
480i	60	YPbPr
480p	60	YPbPr
576i	50	YPbPr
576p	50	YPbPr

Table 24: Technical Specifications of the RGBHV/Comp/YPbPr Output Signal

Resolution	Vertical Frequency (Hz)	Remark	Resolution	Vertical Frequency (Hz)	Remark
640x480	60	VESA	1366x768	60	VESA
640x480	75	VESA	1400x1050	50	
800x600	50		1400x1050	60	VESA
800x600	60	VESA	1600x1200	50	
800x600	75	VESA	1600x1200	60	VESA
1024x768	50		1920x1080	60	VESA
1024x768	60	VESA	1920x1200	60	VESA
1024x768	75	VESA	1680x1050	60	VESA
1280x720	60	VESA	1080i	60	Comp/YPbPr
1280x768	50		1080i	50	
1280x768	60	VESA	720p	60	
1280x800	60	VESA	720p	50	
1280x1024	50		480p	60	
1280x1024	60	VESA	576p	50	
1280x1024	75	VESA	1080p	50	
1366x768	50		1080p	60	

11 VP-725xl Communication Protocol

Communication Confirmation:

Send: CR

Reply: CR>

Set and Get command:

Set Command: Y ■ Control_Type ■ Function ■ Param ■ CR

Reply: Z ■ Control_Type ■ Function ■ Param ■ CR>

Get Command: Y ■ Control_Type ■ Function ■ CR

Reply: Z ■ Control_Type ■ Function ■ Param ■ CR>

Example 1 (set input 1 source type to COMP):

"Y ■ 0 ■ 0 ■ 0 ■ 0 ■ CR"

"Z ■ 0 ■ 0 ■ 0 ■ 0 ■ CR>"

Example 2 (get current input 1 source type):

"Y ■ 1 ■ 0 ■ CR"

"Z ■ 1 ■ 0 ■ 0 ■ CR>"

Definition:

■ : ASCII Code 0x20

CR: ASCII Code 0x0D

After set type Command setting, system will respond a string as "Done".

The default data rate is 9600 Baud, with no parity, 8 data bits and 1 stop bit.

Table 25 includes the Communication Protocol:

Table 25: Communication Protocol of the VP-725xl

Control Type		Function	Parameter	Description
Set	Get			
0	1	5	0: Auto 1: RGB 2: YUV	Input Color Format
0	1	6	0: Auto 1: NTSC 2: PAL 3: PAL-M 4: PAL-N 5: NTSC 4.43 6: SECAM 7: PAL-60	Input Video Standard
0	1	7	0 ~ 400	Input H-Position (the parameter range is set according to the input mode)
0	1	8	0 ~ 100	Input V-Position (the parameter range is set according to the input mode)
0	1	9	-50 ~ 50	Input Frequency (the parameter range is set according to the input mode)
0	1	10	0 ~ 31	Input Phase
0	-	11	N/A	Input Auto Image
0	1	12	-50 ~ 50	Picture Brightness
0	1	13	-50 ~ 50	Picture Contrast
0	1	14	-50 ~ 50	Picture Color
0	1	15	-180 ~ 180	Picture Hue
0	1	16	-50 ~ 50	Picture Sharpness
0	1	17	0: Gamma 1 1: Gamma 2 2: Gamma 3 3: Gamma 4 4: Gamma 5	Picture Output Gamma
0	1	18	0: Auto 1: Video 2: Film	Picture Film Mode
0	1	19	0: Off 1: Low 2: Medium 3: High	Picture Temporal NR
0	1	20	0: Off 1: Low 2: Medium 3: High	Picture Mosquito NR
0	1	21	0: Off 1: On	Picture Block NR
0	1	22	0: Off 1: Low 2: Medium 3: High	Picture Detail Enhancement
0	1	23	0: Off 1: Low 2: High	Picture Luma Transition Enhance
0	1	24	0: Off 1: Low 2: High	Picture Chroma Transition Enhance

VP-725xl Communication Protocol

Control Type		Function	Parameter	Description
Set	Get			
0	1	25	0 : Native HDMI 1 : 640x480@60Hz 2 : 640x480@75Hz 3 : 800x600@50Hz 4 : 800x600@60Hz 5 : 800x600@75Hz 6 : 1024x768@50Hz 7 : 1024x768@60Hz 8 : 1024x768@75Hz 9 : 1280x768@50Hz 10: 1280x768@60Hz 11: 1280x720@60Hz 12: 1280x800@60Hz 13: 1280x1024@50Hz 14: 1280x1024@60Hz 15: 1280x1024@75Hz 16: 1366x768@50Hz 17: 1366x768@60Hz 18: 1400x1050@50Hz 19: 1400x1050@60Hz 20: 1600x1200@50Hz 21: 1600x1200@60Hz 22: 1680x1050@60Hz 23: 1920x1080@60Hz 24: 1920x1200@60Hz 25: 480p@60Hz 26: 576p@60Hz 27: 720p@50Hz 28: 720p@60Hz 29: 1080i@50Hz 30: 1080i@60Hz 31: 1080p@50Hz 32: 1080p@60Hz 96: Custom1 97: Custom2 98: Custom3 99: Custom4	Output Resolution
0	1	26	0: Auto 1: HDMI 2: DVI	Output HDMI Type
0	1	27	0: Best Fit 1: Letterbox 2: Follow Output 3: Virtual Wide 4: Follow Input 5: Custom	Aspect Ratio
0	1	28	-16 ~ 16	H-Pan
0	1	29	-16 ~ 16	V-Pan
0	1	30	-8 ~ 8	H-Zoom
0	1	31	-8 ~ 8	V-Zoom

VP-725xl Communication Protocol

Control Type		Function	Parameter	Description
Set	Get			
0	1	32	0: 100% 1: 150% 2: 200% 3: 225% 4: 250% 5: 275% 6: 300% 7: 325% 8: 350% 9: 375% 10: 400% 11: Custom	Zoom
0	1	33	0 ~ 32	Custom Zoom
0	1	34	-16 ~ 16	Zoom H-Pan
0	1	35	-16 ~ 16	Zoom V-Pan
0	1	36	0: Off 1: On	PIP On/Off
0	1	37	0: Picture-In-Picture 1: Picture + Picture 2: Split	PIP Type
0	1	38	0: VGA1 1: VGA2 2: VGA3 3: VGA4 4: HDMI1 5: HDMI2 6: HDMI3 7: HDMI4 8: COMP1 9: COMP2 10: COMP3 11: COMP4 12: YC1 13: YC2 14: YC3 15: YC4 16: CV1 17: CV2 18: CV3 19: CV4	PIP Source
0	1	39	0: 1/25 1: 1/16 2: 1/9 3: 1/4 4: Custom	PIP Size
0	1	40	0 ~ 128	PIP H-Position
0	1	41	0 ~ 128	PIP V-Position
0	1	42	1 ~ 255	PIP H-Size
0	1	43	1 ~ 255	PIP V-Size
0	1	44	0: Off 1: On	PIP Frame
0	1	45	0: Red 1: Green 2: Blue	PIP Frame Color
0	1	49	-40~0~+40	Audio Bass (not available for VP-725xl)
0	1	50	-40~0~+40	Audio Treble (not available for VP-725xl)
0	1	51	-25~25	Audio Balance (not available for VP-725xl)
0	1	52	0: Off 1: On	Audio Loudness (not available for VP-725xl)

VP-725xl Communication Protocol

Control Type		Function	Parameter	Description
Set	Get			
0	1	53	0: Dynamic 1: User Define	Audio Delay (not available for VP-725xl)
0	1	54	0~340 (step 2)	Audio User Delay (not available for VP-725xl)
0	1	55	0: No audio 1: VGA1 2: VGA2 3: VGA3 4: VGA4 5: HDMI1 6: HDMI2 7: HDMI3 8: HDMI4 9: COMP1 10: COMP2 11: COMP3 12: COMP4 13: YC1 14: YC2 15: YC3 16: YC4 17: CV1 18: CV2 19: CV3 20: CV4	Audio Input For USB (Not available for VP-725xl) (HDMI1 / HDMI2 / HDMI3 / HDMI4 are Not Allowed)
0	1	56	0: Keystone 1: Anyplace 2: Rotation	Geometry Application
0	1	57	0: Front 1: Ceiling 2: Rear 3: Rear ceiling	Geometry Location
0	1	58	-40 ~ 40	Geometry Horizontal Keystone
0	1	59	-30~30	Geometry Vertical Keystone
0	1	60	-2000~2000	Geometry Diagonal Projection - Top Left H
0	1	61	-2000~2000	Geometry Diagonal Projection - Top Left V
0	1	62	-2000~2000	Geometry Diagonal Projection - Top Right H
0	1	63	-2000~2000	Geometry Diagonal Projection - Top Right V
0	1	64	-2000~2000	Geometry Diagonal Projection - Bottom Left H
0	1	65	-2000~2000	Geometry Diagonal Projection - Bottom Left V
0	1	66	-2000~2000	Geometry Diagonal Projection - Bottom Right H
0	1	67	-2000~2000	Geometry Diagonal Projection - Bottom Right V
0	-	68	N/A	Geometry Diagonal Projection – Reset
0	1	69	-20 ~ 20	Geometry Pincushion/Barrel
0	1	70	-180 ~ 180	Geometry Rotation
0	-	71	N/A	Geometry Reset all
0	-	72	0: Profile 1 1: Profile 2 2: Profile 3 3: Profile 4 4: Profile 5 5: Profile 6 6: Profile 7 7: Profile 8	Save Setting

VP-725xl Communication Protocol

Control Type		Function	Parameter	Description
Set	Get			
0	-	73	0: Profile 1 1: Profile 2 2: Profile 3 3: Profile 4 4: Profile 5 5: Profile 6 6: Profile 7 7: Profile 8	Recall Setting
0	1	74	0: Off 1: On	Frame Lock
0	-	75	N/A	Factory Reset
-	1	76	N/A	Firmware Revision
0	1	77	0: 1400x1050x60 1: 1680x1050x60	Mode Set – Mode 1
0	1	78	0: 1280x1024x75 1: 1280x1024x76	Mode Set – Mode 2
0	1	79	0: Center 1: Top Left 2: Top Right 3: Bottom Left 4: Bottom Right	OSD Menu Position
0	1	80	0: 5 sec 1: 10 sec 2: 20 sec 3: 30 sec 4: 60 sec 5: 90 sec 6: Off	OSD Time Out
0	1	81	0: Off 1: On 2: Custom	Logo
0	1	82	0: Black 1: Blue	Blank Color
0	-	83	N/A	Capture
0	1	84	0: Black 1: Blue 2: Custom	Background
0	1	85	0: Off 1: On	Save Lock
0	1	86	0: Off 1: On	Input Lock
0	1	87	0: Blank & Mute 1: Blank 2: Mute	Blank key function If there is no Audio board, parameters = 0 / 2 are not allowed
0	1	88	0: Freeze & Mute 1: Freeze 2: Mute	Freeze key function If there is no Audio board, parameters = 0 / 2 are not allowed
0	1	89	0: Off 1: On	Freeze
0	1	90	0: Off 1: On	Blank
0	1	91	0: Off 1: On	Power
0	-	92	N/A	Info
0	-	93	N/A	Menu
0	-	94	N/A	Top
0	-	95	N/A	Down



VP-725xl Communication Protocol

Control Type		Function	Parameter	Description
Set	Get			
0	-	96	N/A	Volume- (left - button) not available for VP-725xl
0	-	97	N/A	Volume+ (right + button) not available for VP-725xl
0	-	98	N/A	Enter
0	-	99	N/A	Picture
0	-	100	N/A	Swap
0	1	101	0: Off 1: On	Mute (not available for VP-725xl)
0	1	102	0: Off 1: On	Lock
-	1	103	0: 640x480 60 1: 640x480 67, Mac13 2: 640x480 72 3: 640x480 75 4: 640x480 85 5: 720x400 70 6: 720x400 85 7: 800x600 56 8: 800x600 60 9: 800x600 72 10: 800x600 75 11: 800x600 85 12: 832x624 75, Mac16 13: 1024x768 60 14: 1024x768 70 15: 1024x768 75 16: 1024x768 75, Mac19 17: 1024x768 85 18: 1024x800 84, Sun 19: 1152x864 75 20: 1152x870 75, Mac21 21: 1152x900 66, Sun 22: 1152x900 76, Sun 23: 1280x960, 60 24: 1280x960 85 25: 1280x768 60 26: 1280x1024 60 27: 1280x1024 75 28: 1280x1024 76, Sun 29: 1280x1024 85 30: 1400x1050 60 31: 1400x1050 75 32: 1600x1200 60 33: 1680x1050 60 34: 1080i 60 35: 1080i 50 36: 1080p 60 37: 1080p 50 38: 720p 60 39: 720p 50 40: 480i 41: 480p 42: 576i 43: 576p 44: 1280x800 60 (R) 45: 1920x1200 60 46: 1920x1080 60 47: 1280x720 60	Main Input status

VP-725xl Communication Protocol

Control Type		Function	Parameter	Description
Set	Get			
			48: 1080p 24 49: 1280x800 60 50: 1440x900 60 51: 1440x900 60(R) 52: 1280x768 (R) 94: Custom1 95: Custom2 96: Custom3 97: Custom4 98: No Input detected 99: other 101: NTSC 102: PAL 103: PAL-M 104: PAL-N 105: NTSC 4.43 106: SECAM 107: PAL-60	
	1	104	0: 640x480 60 1: 640x480 67, Mac13 2: 640x480 72 3: 640x480 75 4: 640x480 85 5: 720x400 70 6: 720x400 85 7: 800x600 56 8: 800x600 60 9: 800x600 72 10: 800x600 75 11: 800x600 85 12: 832x624 75, Mac16 13: 1024x768 60 14: 1024x768 70 15: 1024x768 75 16: 1024x768 75, Mac19 17: 1024x768 85 18: 1024x800 84, Sun 19: 1152x864 75 20: 1152x870 75, Mac21 21: 1152x900 66, Sun 22: 1152x900 76, Sun 23: 1280x960 60, 24: 1280x960 85 25: 1280x768 60 26: 1280x1024 60 27: 1280x1024 75 28: 1280x1024 76, Sun 29: 1280x1024 85 30: 1400x1050 60 31: 1400x1050 75 32: 1600x1200 60 33: 1680x1050 60 34: 1080i 60 35: 1080i 50 36: 1080p 60 37: 1080p 50 38: 720p 60	PIP Input status



VP-725xl Communication Protocol

Control Type		Function	Parameter	Description
Set	Get			
			39: 720p 50 40: 480i 41: 480p 42: 576i 43: 576p 44: 1280x800 60 (R) 45: 1920x1200 60 46: 1920x1080 60 47: 1280x720 60 48: 1080p 24 49: 1280x800 60 50: 1440x900 60 51: 1440x900 60(R) 52: 1280x768 60(R) 94: Custom1 95: Custom2 96: Custom3 97: Custom4 98: No Input detected 99: other 101: NTSC 102: PAL 103: PAL-M 104: PAL-N 105: NTSC 4.43 106: SECAM 107: PAL-60	
0	1	105	512~3071	Advance Input Mode: HT
0	1	106	32~(HS-48)	Advance Input Mode: HW
0	1	107	80~(HT-HA-12)	Advance Input Mode: HS
0	1	108	640~1920 <= (HT-92)	Advance Input Mode: HA
0	1	109	0: Negative polarity 1: Positive polarity	Advance Input Mode: HP
0	1	110	384~2047	Advance Input Mode: VT
0	1	111	2~(HS-13)	Advance Input Mode: VW
0	1	112	15~(VT-VA-1)	Advance Input Mode: VS
0	1	113	480~1200 <= (VT-16)	Advance Input Mode: VA
0	1	114	0: Negative polarity 1: Positive polarity	Advance Input Mode: VP
0	1	115	25 < OCLK < 165	Advance Input Mode: OCLK(Integer)
0	1	116	25 < OCLK < 165	Advance Input Mode: OCLK(Decimal)
0	1	117	0: Off 1: On	Advance Input Mode: Enable
0	-	118	N/A	Advance Input Mode: Save
0	1	119	512~3071	Advance Output Mode: HT
0	1	120	32~(HS-48)	Advance Output Mode: HW
0	1	121	80~(HT-HA-12)	Advance Output Mode: HS
0	1	122	640~1920 <= (HT-92)	Advance Output Mode: HA
0	1	123	0: Negative polarity 1: Positive polarity	Advance Output Mode: HP
0	1	124	384~2047	Advance Output Mode: VT
0	1	125	2~(HS-13)	Advance Output Mode: VW
0	1	126	15~(VT-VA-1)	Advance Output Mode: VS

VP-725xl Communication Protocol

Control Type		Function	Parameter	Description
Set	Get			
0	1	127	480~1200 ≤ (VT-16)	Advance Output Mode: VA
0	1	128	0: Negative polarity 1: Positive polarity	Advance Output Mode: VP
0	1	129	25 < OCLK < 165	Advance Output Mode: OCLK(Integer)
0	1	130	25 < OCLK < 165	Advance Output Mode: OCLK(Decimal)
0	-	131	N/A	Advance Output Mode: Save
0	-	132	N/A	Advance Output Mode: Set Current
0	1	135	0: Follow Output 1: Follow Input	HDCP Setting
0	1	136	0: Custom1 1: Custom2 2: Custom3 3: Custom4	Advance Input Mode: Custom Input
0	1	137	0: Custom1 1: Custom2 2: Custom3 3: Custom4	Advance Output Mode: Custom Output
0	1	138	0: Off 1: On	Overscan
0	1	139	0: Seamless 1: Fast	Switching Mode
0	1	140	0: Manual 1: Auto	Auto Image Mode
0	-	141	N/A	Slideshow Start
0	-	142	N/A	Slideshow Stop
0	-	143	N/A	Slideshow Pause
0	-	144	N/A	Slideshow Next
0	-	145	N/A	Slideshow Previous
0	1	146	0: Min 1: Low 2: Mid 3: Long 4: Max 5: Off	Slideshow
0	1	151	0: Video Group 1: Audio Group 2: AV Group 3: Scaler 4: Master Audio 5: Master AV	Group / Master SELECT Note : Error when SELECT ≠ Video Group / Audio Group / AV Group If there is no Audio board, parameters = 1 / 2 / 4 / 5 are not allowed
0	1	152	0: VGA1 1: VGA2 2: VGA3 3: VGA4	Select VGA group channel Note : Error when SELECT ≠ Video Group / Audio Group / AV Group
0	1	153	0: HDMI1 1: HDMI2 2: HDMI3 3: HDMI4	Select HDMI group channel Note : Error when SELECT ≠ Video Group / Audio Group / AV Group
0	1	154	0: COMP1 1: COMP2 2: COMP3 3: COMP4	Select COMP group channel Note : Error when SELECT ≠ Video Group / Audio Group / AV Group
0	1	155	0: YC1 1: YC2 2: YC3 3: YC4	Select YC group channel Note : Error when SELECT ≠ Video Group / Audio Group / AV Group

VP-725xl Communication Protocol

Control Type		Function	Parameter	Description
Set	Get			
0	1	156	0: CV1 1: CV2 2: CV3 3: CV4	Select CV group channel Note : Error when SELECT ≠ Video Group / Audio Group / AV Group
0	1	157	0: VGA1 1: VGA2 2: VGA3 3: VGA4 4: HDMI1 5: HDMI2 6: HDMI3 7: HDMI4 8: COMP1 9: COMP2 10: COMP3 11: COMP4 12: YC1 13: YC2 14: YC3 15: YC4 16: CV1 17: CV2 18: CV3 19: CV4 20: USB	Select Master Input channel Note : Error when SELECT ≠ Scaler / Master Audio / Master AV
0	1	158	0: All Off 1: Override 2: Mix 3: Talk Over	MIC Control (not available for VP-725xl)
0	1	159	-30 ~ +10	VGA Group In Volume (not available for VP-725xl)
0	1	160	-30 ~ 10	VGA Group Out Volume (not available for VP-725xl)
0	1	161	-30 ~ +10	HDMI Group In Volume (not available for VP-725xl)
0	1	162	-30 ~ 10	HDMI Group Out Volume (not available for VP-725xl)
0	1	163	-30 ~ +10	COMP Group In Volume (not available for VP-725xl)
0	1	164	-30 ~ 10	COMP Group Out Volume (not available for VP-725xl)
0	1	165	-30 ~ +10	YC Group In Volume (not available for VP-725xl)
0	1	166	-30 ~ 10	YC Group Out Volume (not available for VP-725xl)
0	1	167	-30 ~ +10	CV Group In Volume (not available for VP-725xl)
0	1	168	-30 ~ 10	CV Group Out Volume (not available for VP-725xl)
0	1	169	-30 ~ +10	Master In Volume (not available for VP-725xl)
0	1	170	-100 ~ 24	Master Out Volume (not available for VP-725xl)
0	1	171	-100 ~ 24	MIC In Volume (not available for VP-725xl)
0	1	172	0: OSD ON = disable 1: OSD ON = enable	To Enable / Disable OSD ON
0	1	173	0: Pip source select = 0 1: Pip source select = 1	Hot key PIP source select, same as remote control key - PIP Source
0	1	174	0: 1/25 (for Get Command) 1: 1/16 (for Get Command) 2: 1/9 (for Get Command) 3: 1/4 (for Get Command)	Hot key PIP size, same as remote control key - PIP Size Note: For set function command, parameter will be ignore
0	-	175	N/A	Hot key Master Audio, same as remote control / Keypad - Master Audio of SELECT (not available for VP-725xl)
0	-	176	N/A	Hot key Scaler, same as remote control / Keypad - Scaler of SELECT

VP-725xl Communication Protocol

Control Type		Function	Parameter	Description
Set	Get			
0	-	177	N/A	Hot key Audio Group, same as remote control / Keypad - Audio Group of SELECT (not available for VP-725xl)
0	-	178	N/A	Hot key Video Group, same as remote control / Keypad - Video Group of SELECT (not available for VP-725xl)
0	1	179	10: Audio Level = Master In 11: Audio Level = Master Out 12: Audio Level = Mic In 13: Audio Level = Off	Hot key Audio Level , same as remote control / Keypad - Audio Level Note : parameter must be in the range of 10 ~ 13, or it will have no effect (not available for VP-725xl)
0	-	180	N/A	Hot key Override, same as remote control / Keypad - Override
0	-	181	N/A	Hot key Talk Over, same as remote control / Keypad - Talk Over
0	-	182	N/A	Hot key Mix, same as remote control / Keypad - Mix
0	-	183	N/A	VGA Group Output Volume Increase (not available for VP-725xl)
0	-	184	N/A	VGA Group Output Volume Decrease (not available for VP-725xl)
0	-	185	N/A	HDMI Group Output Volume Increase (not available for VP-725xl)
0	-	186	N/A	HDMI Group Output Volume Decrease (not available for VP-725xl)
0	-	187	N/A	COMP Group Output Volume Increase (not available for VP-725xl)
0	-	188	N/A	COMP Group Output Volume Decrease (not available for VP-725xl)
0	-	189	N/A	YC Group Output Volume Increase (not available for VP-725xl)
0	-	190	N/A	YC Group Output Volume Decrease (not available for VP-725xl)
0	-	191	N/A	CV Group Output Volume Increase (not available for VP-725xl)
0	-	192	N/A	CV Group Volume Decrease (not available for VP-725xl)
0	-	193	N/A	MASTER Group Output Volume Increase (not available for VP-725xl)
0	-	194	N/A	MASTER Group Output Volume Decrease (not available for VP-725xl)

11.1 Error Codes

Table 26: The Error Codes

Error code	Description
ERR 1	Unknown command
ERR 2	Unknown function
ERR 3	Unavailable function
ERR 4	Unknown control type
ERR 5	Unavailable get function
ERR 6	Unavailable set function
ERR 7	Unavailable parameter
ERR 8	Too few arguments



LIMITED WARRANTY

Kramer Electronics (hereafter *Kramer*) warrants this product free from defects in material and workmanship under the following terms.

HOW LONG IS THE WARRANTY

Labor and parts are warranted for seven years from the date of the first customer purchase.

WHO IS PROTECTED?

Only the first purchase customer may enforce this warranty.

WHAT IS COVERED AND WHAT IS NOT COVERED

Except as below, this warranty covers all defects in material or workmanship in this product. The following are not covered by the warranty:

1. Any product which is not distributed by Kramer, or which is not purchased from an authorized Kramer dealer. If you are uncertain as to whether a dealer is authorized, please contact Kramer at one of the agents listed in the Web site www.kramerelectronics.com.
2. Any product, on which the serial number has been defaced, modified or removed, or on which the WARRANTY VOID IF TAMPERED sticker has been torn, reattached, removed or otherwise interfered with.
3. Damage, deterioration or malfunction resulting from:
 - i) Accident, misuse, abuse, neglect, fire, water, lightning or other acts of nature
 - ii) Product modification, or failure to follow instructions supplied with the product
 - iii) Repair or attempted repair by anyone not authorized by Kramer
 - iv) Any shipment of the product (claims must be presented to the carrier)
 - v) Removal or installation of the product
 - vi) Any other cause, which does not relate to a product defect
 - vii) Cartons, equipment enclosures, cables or accessories used in conjunction with the product

WHAT WE WILL PAY FOR AND WHAT WE WILL NOT PAY FOR

We will pay labor and material expenses for covered items. We will not pay for the following:

1. Removal or installation charges.
2. Costs of initial technical adjustments (set-up), including adjustment of user controls or programming. These costs are the responsibility of the Kramer dealer from whom the product was purchased.
3. Shipping charges.

HOW YOU CAN GET WARRANTY SERVICE

1. To obtain service on your product, you must take or ship it prepaid to any authorized Kramer service center.
2. Whenever warranty service is required, the original dated invoice (or a copy) must be presented as proof of warranty coverage, and should be included in any shipment of the product. Please also include in any mailing a contact name, company, address, and a description of the problem(s).
3. For the name of the nearest Kramer authorized service center, consult your authorized dealer.

LIMITATION OF IMPLIED WARRANTIES

All implied warranties, including warranties of merchantability and fitness for a particular purpose, are limited in duration to the length of this warranty.

EXCLUSION OF DAMAGES

The liability of Kramer for any effective products is limited to the repair or replacement of the product at our option. Kramer shall not be liable for:

1. Damage to other property caused by defects in this product, damages based upon inconvenience, loss of use of the product, loss of time, commercial loss; or
2. Any other damages, whether incidental, consequential or otherwise. Some countries may not allow limitations on how long an implied warranty lasts and/or do not allow the exclusion or limitation of incidental or consequential damages, so the above limitations and exclusions may not apply to you.

This warranty gives you specific legal rights, and you may also have other rights, which vary from place to place.

NOTE: All products returned to Kramer for service must have prior approval. This may be obtained from your dealer.

This equipment has been tested to determine compliance with the requirements of:

- EN-50081: "Electromagnetic compatibility (EMC);
generic emission standard."
Part 1: Residential, commercial and light industry"
- EN-50082: "Electromagnetic compatibility (EMC) generic immunity standard."
Part 1: Residential, commercial and light industry environment".
- CFR-47: FCC* Rules and Regulations:
Part 15: "Radio frequency devices
Subpart B Unintentional radiators"

CAUTION!

- Servicing the machines can only be done by an authorized Kramer technician. Any user who makes changes or modifications to the unit without the expressed approval of the manufacturer will void user authority to operate the equipment.
- Use the supplied DC power supply to feed power to the machine.
- Please use recommended interconnection cables to connect the machine to other components.
* FCC and CE approved using STP cable (for twisted pair products)



For the latest information on our products and a list of Kramer distributors, visit our Web site: www.kramerelectronics.com, where updates to this user manual may be found. We welcome your questions, comments and feedback.

 <p>Caution</p>	<p>Safety Warning: Disconnect the unit from the power supply before opening/servicing.</p>
---	---



Kramer Electronics, Ltd.
Web site: www.kramerelectronics.com
E-mail: info@kramerel.com
P/N: 2900-000397 REV 2