

Preparations

Connecting the Cables to the Camera

Before installation, connect the supplied cables to the camera as required for your usage and wire them.

- Remove the screw on the bottom of the camera unit to detach the cable cover.
- Pass the cables through the hole on the bottom of the camera unit.
- Connect the cables to the connectors on the camera unit.
 - Ⓐ I/O cable: to EXT CTRL connector
 - Ⓑ BNC cable: to VIDEO OUT connector
 - Ⓒ Audio cable: to AUDIO connector
- Wire the cables along the cable guides on the camera unit. Position the cables under the cable clamps.

Note

To prevent the cables from being trapped by the dome casing, be sure to wire them using the cable guides and clamps.

- Pull the cables gently from the bottom of the camera unit to take in the slack, and fix the cable cover with the screw.
- To install the camera for indoor wiring, push the indoor wiring cover outwards and then remove it and pass the cables through it.

Installation

WARNING

- If you attach the camera in the height such as the wall or the ceiling, etc., entrust the installation to an experienced contractor or installer.
- If you install the camera on the ceiling, ensure that the ceiling is strong enough to withstand the weight of the camera plus the bracket and then install the camera securely. If the ceiling is not strong enough, the camera may fall and cause serious injury.
- To prevent the camera from falling, make sure to attach the supplied wire rope.
- If you attach the camera to the ceiling, check periodically, at least once a year, to ensure that the connection has not loosened. If conditions warrant, make this periodic check more frequently.

Deciding the Installation Location of the Camera

After deciding the direction in which the camera will shoot, make the required hole (ø 50 mm (2 inches)) for the connecting cables using the supplied template. Then decide the two or four mounting hole positions to install the bracket.

Mounting screws

The supplied bracket is provided with ø 4.5 mm (1/16 inch) mounting holes. Install the bracket on a ceiling or wall with screws through two or four mounting holes: two 83.5 mm (3 3/16 inches)-pitched holes or four 85.7 mm (3 3/8 inches)-pitched holes. The required mounting screws differ depending on the installation location and its material. (Mounting screws are not supplied.)

Steel wall or ceiling: Use M4 bolts and nuts.
Wooden wall or ceiling: Use M4 tapping screws. The panel thickness must be 15 mm (1/2 inch) or more.
Concrete wall: Use anchors, bolts and plugs suitable for concrete walls.
Junction box: Use screws to match the holes on the junction box.

WARNING

The required mounting screws differ depending on the installation location and its material. If you do not secure the camera with the appropriate mounting screws, the camera may fall off.

Installing the Camera

- Remove the dome casing.
 - Pull out the screw cover and loosen the screw with a screwdriver.
 - Turn the dome casing to the curved mark position on the camera unit, and remove the dome casing from the camera unit. When the screw catches on the screw hole, pull up the screw.
- Install the supplied bracket on the ceiling or wall.
 - Loosen the screw with the wrench (supplied).
 - Turn the dome casing to the curved mark position on the camera unit, and remove the dome casing from the camera unit. When the screw catches on the screw hole, pull up the screw.
- Fix the supplied wire rope to the camera unit and the ceiling or wall.
 - Fix the wire rope with the supplied shoulder screw to the hole for the wire rope on the bottom of the camera unit. Pass the wire rope between the wire rope guides.
 - Fix the wire rope to the ceiling or wall.
- Attach the camera unit to the bracket.
 - Insert the supplied two camera unit mounting screws into the two mounting holes of the camera. The screws have a fall-prevention mechanism. The screws inserted into the screw holes of the camera unit do not fall even if you turn the camera unit upside down.
 - Align the notch on the camera with the Δ mark on the bracket.
 - Turn the camera unit in the direction of the arrow.
 - Tighten the camera unit mounting screws.

Notes

- Use the supplied screws for installation. otherwise, you may not install the camera unit properly, even a falling may occur.
- If you cannot use screws on a ceiling or wall, or if you want to make the camera less conspicuous, use the YT-ICB45/YT-ICB140 in-ceiling bracket (optional) with which you can mount the camera on the ceiling. For this model, install the camera to the [B] position on the side brackets of YT-ICB45/YT-ICB140. Refer to the Installation Instructions of YT-ICB45/YT-ICB140 for detail information.

Adjusting the Camera Direction and Coverage

- Loosen the camera head fixing screw.
- Adjust the camera to turn the lens in the desired direction.
- Tighten the camera head fixing screw to fix the camera.
- Slide the ZOOM/FOCUS switch to W/T to adjust the zoom. The zoom indicator is displayed on the monitor.
- Press the Easy Focus button to automatically adjust the focus.
- Repeat steps 1 to 5 until the coverage and the focus are determined.

Notes

- When you adjust the camera head angle without loosening camera head fixing screw, an internal part may be damaged.
 - When the lens is not put in the slit of the camera head holder, the moving range of the camera head is limited.
 - If the camera head is too heavy to be adjusted, loosen the camera head fixing screw until it moves freely.
 - When adjusting the angle, be sure that the TOP mark on the camera head section faces the ceiling. If the camera is installed with the TOP mark facing the floor, the image appears upside down.
 - If you cannot achieve satisfactory focus with the Easy Focus button due to the shooting environment, slide the ZOOM/FOCUS switch level to N/F to focus manually. The focus indicator is displayed on the monitor.
 - Poor focus may also be caused by the dome case assembly. Readjust the focus using the system menu.
- For details, refer to the User Guide of the equipment.

Note

Do not turn the lens more than 360 degrees, as this may damage the wiring inside, which may cause failure on video output.

Attaching the Dome Casing

- Align the carved mark on the dome casing with that on the camera unit, and turn the dome casing in the direction of the arrow.
- Secure the screw. Only the SNC-DH140/240 cover should be attached.
- Remove the protecting film on the dome cover.

Connection

Connecting to the Network

Connect the LAN cable of the camera to a router or hub in the network using the network cable (straight, not supplied).

To connect to a computer

Connect the LAN cable of the camera to the network connector of a computer using the network cable (cross, not supplied).

Connecting the Power Source

There are three ways to supply the power source to this camera, as follows.

- 12 V DC
 - 24 V AC
 - Power supply equipment pursuant to IEEE802.3af (PoE) system
- *PoE means Power over Ethernet.

Connecting to 12 V DC or 24 V AC source

Connect the power input cable of the camera to a 12 V DC or 24 V AC source. Use a 12 V DC or 24 V AC source isolated from 100 to 240 V AC. Each usable voltage ranges are as follows.

- 12 V DC: 10.8 V to 13.2 V
- 24 V AC: 21.6 V to 26.4 V
 - In the USA, The product shall be powered by a UL Listed Class 2 Power Supply Only.
 - In Canada, The product shall be powered by a CSA certified Class 2 Power Supply Only

Use UL cable (VW-1 style 10368) for these connections.

recommended cable

CABLE(AWG)	#24	#22	#20
DC12 V:			
Max. length(m)	9	15	23
AC24 V:			
Max. length(m)	37	63	92

Connecting to the power supply equipment pursuant to IEEE802.3af

The power supply equipment pursuant to IEEE802.3af supplies the power through the LAN cable. For details, refer to the Instruction Manual of the equipment.

Connecting the I/O Cable

Connect the wires of the I/O cable as follows:

Wiring diagram for sensor input

Mechanical switch/open collector output device

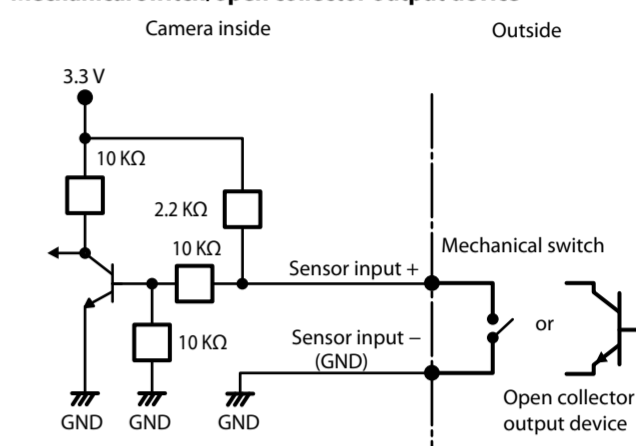

Wiring diagram for alarm output

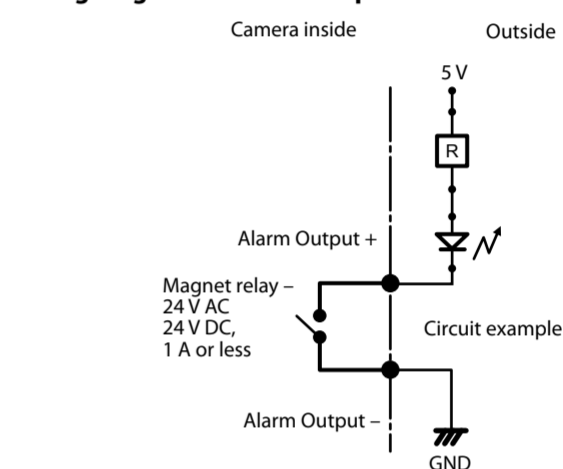

Specifications

Compression	JPEG/MPEG4/H.264
Video compression format	G.711/G.726 (40, 32, 24, 16 kbps)
Audio compression format	SNC-DH140/DH140T
Maximum frame rate	H.264: 30 fps (1280 × 720) SNC-DH240/DH240T H.264: 30 fps (1920 × 1080)

Camera	NTSC color system/PAL color system (switchable)
Signal system	SNC-DH140/DH140T
Image device	1/3type CMOS (Exmor) Effective picture elements: Approx. 1,390,000
	SNC-DH240/DH240T
	1/2.8type CMOS (Exmor) Effective picture elements: Approx. 3,270,000
Synchronization	Internal synchronization
Horizontal resolution	600 TV lines (analog video)
Video S/N	More than 50 dB (AGC 0 dB)
Minimum illumination	SNC-DH140/DH140T F1.2/View-DR Off/VE Off/AGC High/XDNR Middle/50 IRE (IP) Color 0.20 lx Black & White 0.10 lx SNC-DH240/DH240T F1.2/View-DR Off/VE Off/AGC High/XDNR Middle/50 IRE (IP) Color 0.40 lx Black & White 0.25 lx

Lens	3.1 mm to 8.9 mm
Focal length	F1.2 ~ F2.1
Maximum relative aperture	SNC-DH140/DH140T
View angle	Vertical: 67.4° to 25.0° (1280 × 1024) Horizontal: 85.4° to 31.2° SNC-DH240/DH240T Vertical: 65.2° to 24.2° (1920 × 1440) Horizontal: 88.5° to 32.3°
Minimum object distance	300 mm

Interface	10BASE-T/100BASE-TX, auto negotiation (RJ-45)
LAN port	Sensor input: × 1, make contact, break contact
I/O port	Alarm output: × 2, 24 V AC/DC, 1 A (mechanical relay outputs electrically isolated from the camera)

Video output	VIDEO OUT: BNC, 1.0 Vp-p, 75 ohms, unbalanced, sync negative
Microphone input*	Minijack (monaural) Plug-in-power supported (rated voltage: 2.5 V DC) Recommended load impedance: 2.2 kΩ

Line input*	Minijack (monaural)
* The microphone input and the line input are switchable with operating menu.	
Line output	Minijack (monaural), Maximum output level: 1 Vrms

Others	12 V DC ± 10%
Power supply	24 V AC ± 10%, 50 Hz/60 Hz IEEE802.3af compliant (PoE system)
Power consumption	SNC-DH140/DH140T: 8.0 W max. SNC-DH240/DH240T: 10.2 W max.
Operating temperature	Start temperature: 0°C ~ 50°C (32°F to 122°F) Working temperature: -10°C ~ +50°C (14°F to 122°F)
Storage temperature	-20°C to +60°C (-4°F to +140°F)
Operating humidity	20% to 80%
Storage humidity	20% to 95%
Dimensions (diameter/height)	SNC-DH140/DH240: 140 mm × 118 mm (5 5/8 inches × 4 3/4 inches) SNC-DH140T/DH240T: 140 mm × 119 mm (5 5/8 inches × 4 3/4 inches) SNC-DH140/DH240: Approx. 750 g (1 lb 10 oz), not including the cables and bracket SNC-DH140T/DH240T: Approx. 980 g (2 lb 2.6 oz), not including the cables and bracket

Mass	Approx. 750 g (1 lb 10 oz), not including the cables and bracket
Supplied accessories	CD-ROM (User's Guides, and supplied programs) (1), Bracket (1), Template (1), Wire rope (1), Camera unit mounting screws (2), Shoulder screw M4 (1), Wrench (SNC-DH140T/DH240T) (1), Audio cable (1), I/O cable (1), LAN cable (1), BNC cable (1), Power input cable (1), Installation Manual (this document) (1 set)

Optional accessory
In-ceiling bracket YT-ICB45*, YT-ICB140*
* Using the fixture position [B] on the bracket.

Design and specifications are subject to change without notice.

Recommendation of Periodic Inspections

In case using this device over an extended period of time, please have it inspected periodically for safe use. It may appear flawless, but the components may have deteriorated over time, which may cause a malfunction or accident. For details, please consult the store of purchase or an authorized Sony dealer.